

SPECIFICATION SHEET

COLLECTION: OMIKA NOIR

PRODUCT CODE: IND-T148/2-OMI-PB



DESCRIPTION:

Tablet Omika vertical concealed
2 outlet 2 handle thermostatic shower valve
with all-flow function
wall mounted
thermostatic cartridge V-001C-PLA
diverter cartridge FL-802-33/2MX
2 x 3/4" female inlets
2 x 3/4" female outlets
includes 3/4" - 1/2" adaptors
supplied with mortar/tile guard
min-max wall mount 75-100mm
optimum installation depth 87mm
minimum operating pressure
0.2 bar LP (shower) 1.0 bar MP (bath)

FINISH:

Polished Black

MINIMUM OPERATING PRESSURE:

0.2 bar LP (shower) 1.0 bar MP (bath)



tel: 01934 744466
email: sales@vado.com
www.vado.com

where inspiration flows
taps | showering | accessories



TECHNICAL DRAWING

COLLECTION: OMIKA NOIR

PRODUCT CODE: IND-T148/2-OMI-PB

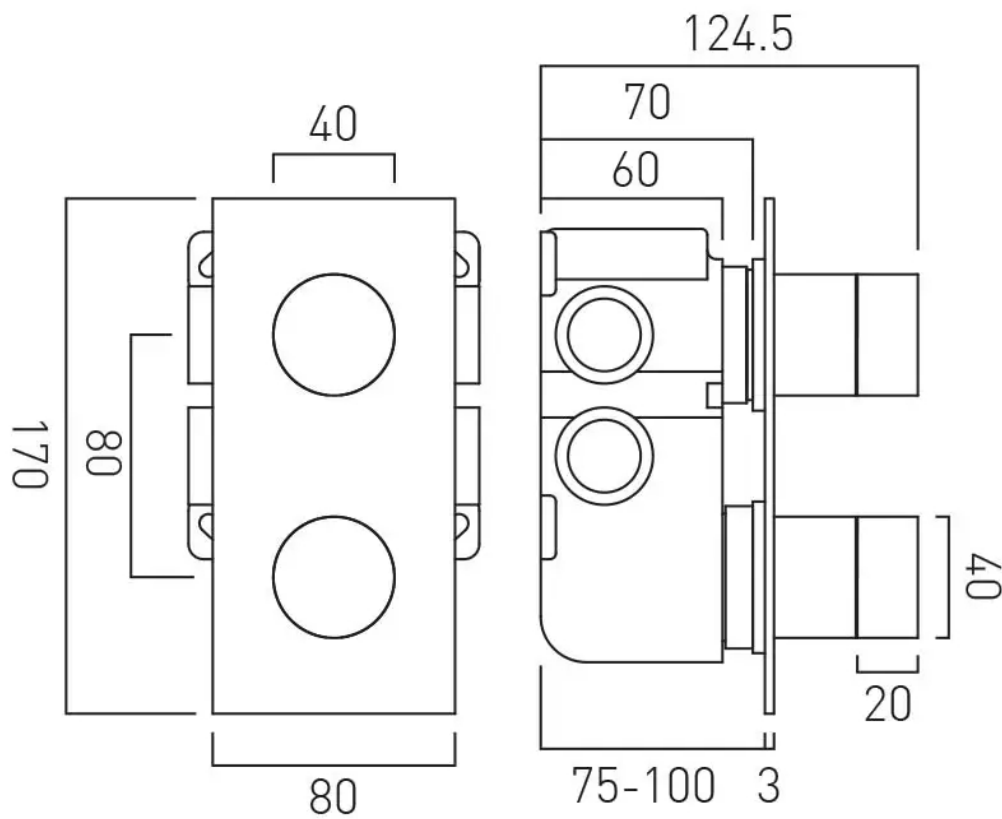

tel: 01934 744466
email: sales@vado.com
www.vado.com

where inspiration flows
taps | showering | accessories



Guarantee

All VADO products come with a 2 year guarantee as standard. Within this guarantee period VADO will provide replacement parts and any labour **[SEE NOTE 1]** needed to complete the product repair.

This standard guarantee may be extended by registering your product to give the following guarantee periods, once registered:

Brassware products from the Individual by VADO collection have a 15 year guarantee (2 years parts and labour plus 13 years parts only).

VADO Sensori SmartTouch and SmartDial products have a 5 year guarantee (parts and labour). VADO Identity and i-tech products have a 5 year guarantee (2 year parts and labour plus 3 years parts only).

All other VADO products have a 3 year guarantee (2 years parts and labour plus 1 year parts only)

[SEE NOTE 2].

Guarantee Conditions

Our products are guaranteed against manufacturing defects from the date of purchase until the expiry of the relevant guarantee period shown above.

The guarantee is only valid if:

- The product has been installed, used and maintained in accordance with VADO's instructions and subjected to normal use only.
- The defect is not due to use of an unsuitable or inadequate water or power supply.
- The defect is not due to accident, misuse, neglect or incorrect/inappropriate repair (other than by VADO or VADO authorised agents) or damage caused by foreign objects or substances.
- The extended guarantee is only available if you have completed the Guarantee Registration Process.

This can be done via the VADO website or via phone to our aftersales team.

Registration must be completed within 6 months from date of purchase.

Under the extended guarantee period VADO will, at its option, offer to supply any replacement product (or component part) assessed to be defective **[SEE NOTE 3]**.

The guarantee (whether standard or extended) is non-transferable to any subsequent owner.

All claims under the guarantee should be notified in the first instance to our Aftersales department, contact details below, this must be done no later than the last day of the relevant guarantee period.

All claims must be accompanied by proof of purchase (sales receipt or delivery note) from an official VADO dealer.

The guarantee does not extend to any consequential loss or damage.

After repair or replacement, the relevant guarantee period will be calculated from the original date of purchase.

VADO operates a policy of continuous product development and therefore reserves the right to change the product, packaging and documentation specifications without notice. E&OE.

NOTES:

[1] Labour via our engineer network is only available in the UK. Attendance by a VADO engineer or sub-contract engineer will be under our standard terms and conditions.

[2] VADO spare parts and shower hoses are under a parts only guarantee.

[3] VADO reserves the right to charge in advance for a product (or replacement part) pending collection and investigation (at VADO expense) to confirm a defect is due to a manufacturing issue.

If a defect is found the charge will be refunded or cancelled.

This guarantee is in addition to and does not affect your statutory rights as a consumer.

Tel: 01934 745163

Email: aftersales@vado.com

KEEP FOR
FUTURE REFERENCE

15
year guarantee

OMIKA *NOIR*

—
2 WAY THERMOSTATIC SHOWER VALVE
USER GUIDE



INDIVIDUAL

by VADO

Welcome

Thank you for selecting Individual by VADO.

Each timeless finish has been tailored to inspire your individual style, ready for you to create a contemporary look that will stand the test of time.

Coupled with our leading 15 year guarantee, this premium product has passed through stringent quality assurance processes to allow you to complete your look with confidence.

Our outstanding customer service, large scale development support and prestigious project history has ensured a globally trusted reputation. For any technical or operation queries, please contact our experienced Aftersales team on 01934 745 163.

Cleaning instructions:

The physical vapor deposition coating on this product is finished to the highest standard. Due care needs to be taken to ensure the appearance is retained. We recommend cleaning all products with a soft damp cloth **ONLY** and advise strongly against the use of all aggressive/corrosive cleaning products i.e. powders and liquids. If these instructions are not followed, this may invalidate your guarantee in the event of a problem occurring.

VADO, Wedmore Road, Cheddar, Somerset, England BS27 3EB
tel 01934 744466 fax 01934 744345
aftersales@vado.com
www.vado.com

Operation - flow control

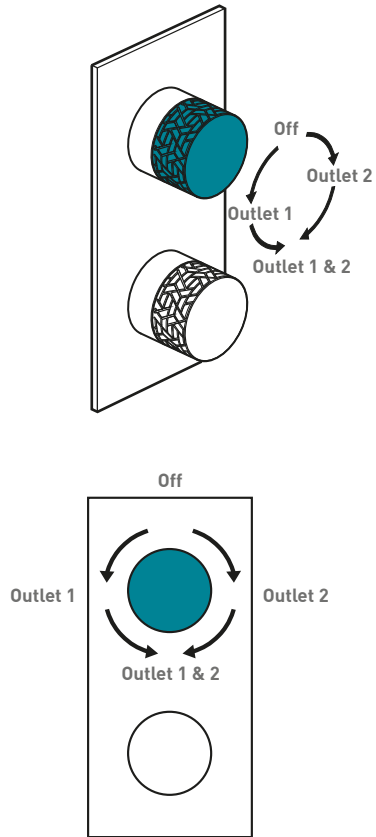

Turning the flow control handle in the direction of the arrow increases the flow of water to the outlet.

Operation - temperature control

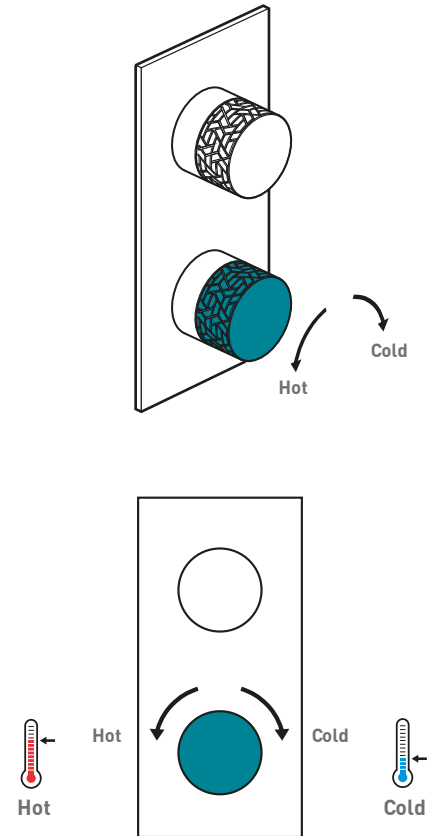

Turning the temperature control handle in the direction of the arrows increases/decreases the temperature

Parts list:

Item	Code	Quantity
1	FL-802-33/2MX	1
2	V-704-34S	1
3	TAB-003A-FIL	1
4	TAB-003A-FIL-HOUSING	1
5	TAB-STOPRING	1
6	TAB-NUT/TEMP-BRA	1
7	TAB-NUT/FLOW-BRA	1
8	TAB-DIV/EXTSPLINE-BR	1
9	TAB-COG-BRA	1
10	TAB-DIV/COVERNUT-BRA	1
11	CEL-CON-3/4MX1/2F-BR	1
12	INSTALLATION GUIDE & USER MANUAL	1

Parts:

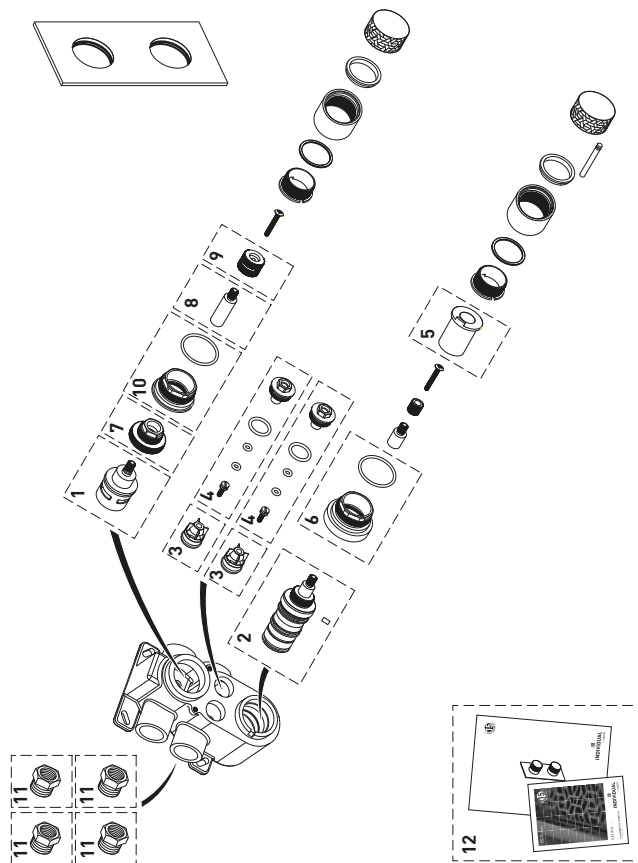



INDIVIDUAL
by VADO

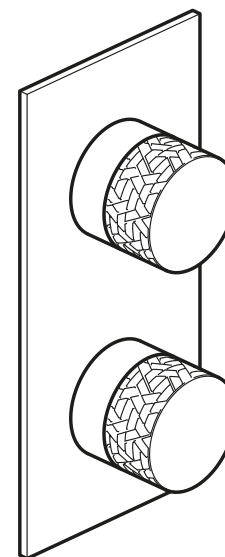

OMIKA NOIR

2 way thermostatic shower valve

—

INSTALLATION GUIDE

VADO
Wedmore Road, Cheddar,
Somerset, England BS27 3EB
tel 01934 744466
fax 01934 744345
www.vado.com
sales@vado.com

Version 1, 1-7-2021

INDIVIDUAL
by VADO

Important - please read

Please read these instructions carefully before starting installation and keep for future reference.

Remove all packaging and check the product for missing parts or damage before starting installation.

Any alterations made to this product and fittings may infringe water regulations and will invalidate the guarantee.

The installation must comply with all Local/National Water Supply Authority Regulations/Byelaws and Building and Plumbing Regulations.

To be installed in accordance with BS EN806.

We strongly recommend that you use a qualified and registered plumber.

General installation

This fitting is a mixing device and therefore water supplies should be reasonably balanced.

When installed, the fitting must comply with the requirements of the Water Supply (Water Fittings) Regulations 1999 and Scottish Byelaws 2004.

For further information, contact the Water Regulations department of your local water supplier (see the WRAS website www.wras.co.uk for details) or the Water Regulations Advisory Scheme by email (info@wras.co.uk) or telephone: 01495848454.

Before making any inlet pipe connections, all supply pipes MUST be thoroughly flushed to remove debris. Failure to do so could result in damage or low flow from the mixer unit.

The fitting of isolating valves to the inlet feeds is advised for ease of maintenance.

Please take great care when installing this mixer not to damage its surface.

Please note if installing in an enclosed environment, access should be left for servicing and maintenance. No costs relating to inadequate access can be accepted.

Operating Specifications

Operating Pressure

Minimum operating pressure **0.2 bar** (**1 bar** if used as a bath fill)

Maximum operating pressure **5 bar**

Contents of Packaging



Installation guide &
User manual

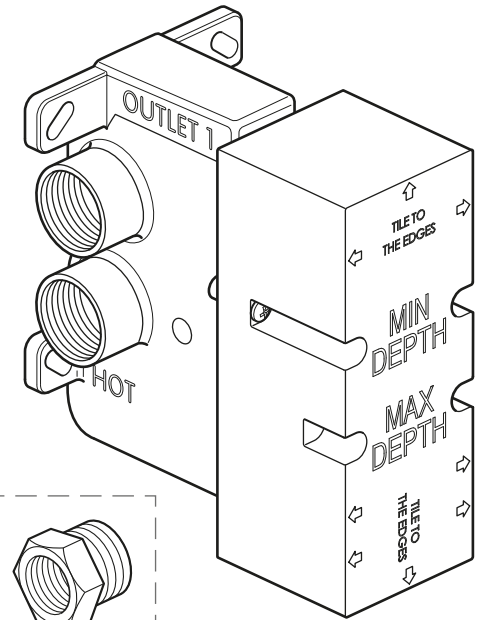

Valve with
mortar cover

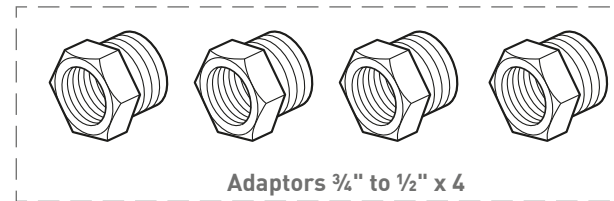

Adaptors 3/4" to 1/2" x 4

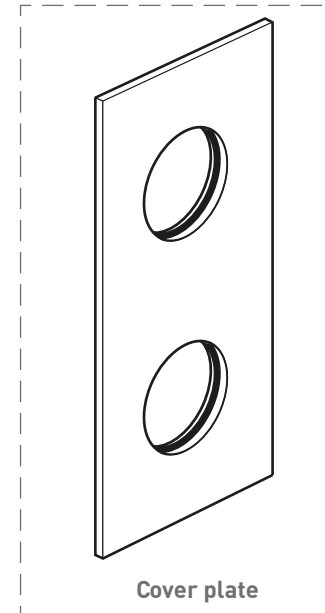

Cover plate

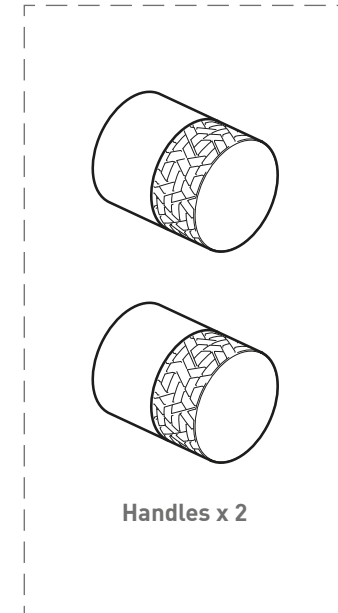

Handles x 2

Dimensions

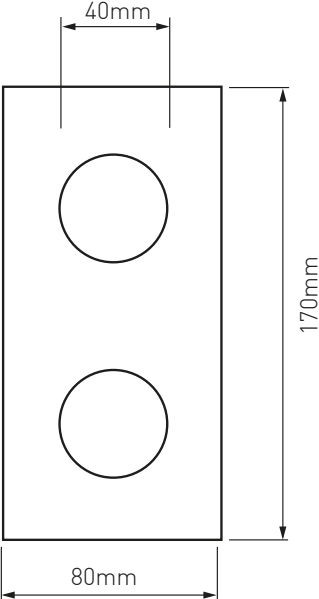
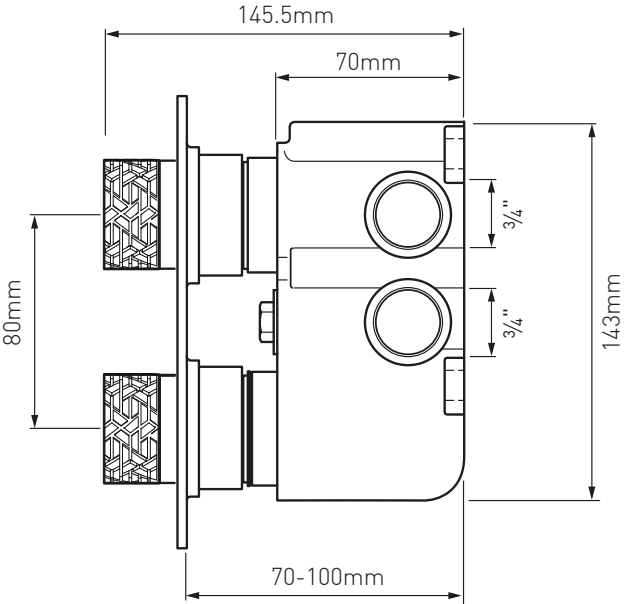

Installation - Quick guide

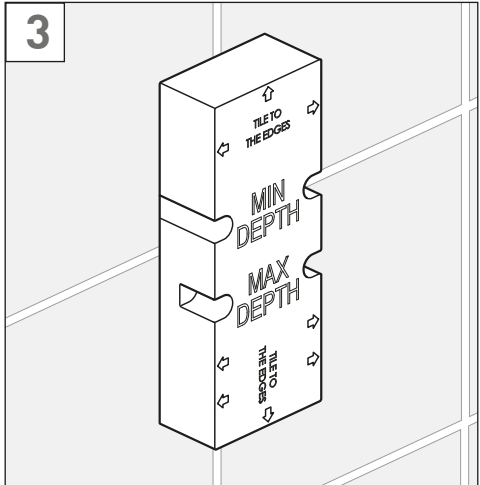
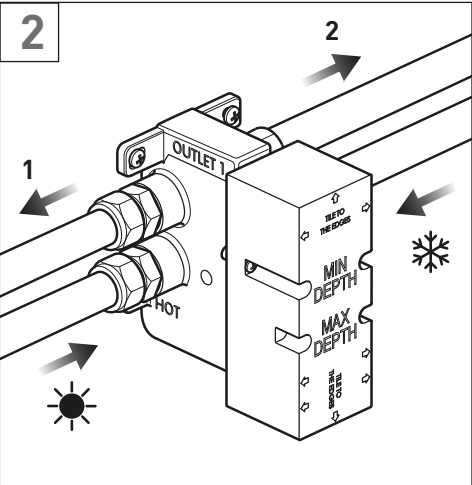
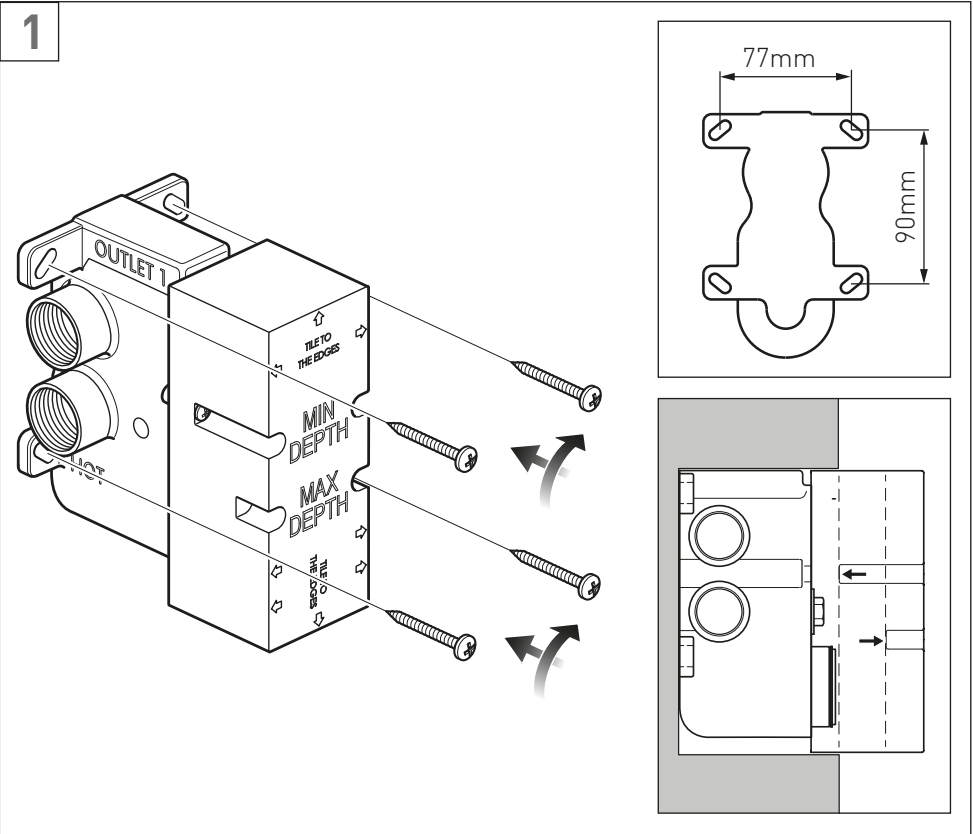

Installation - Quick guide

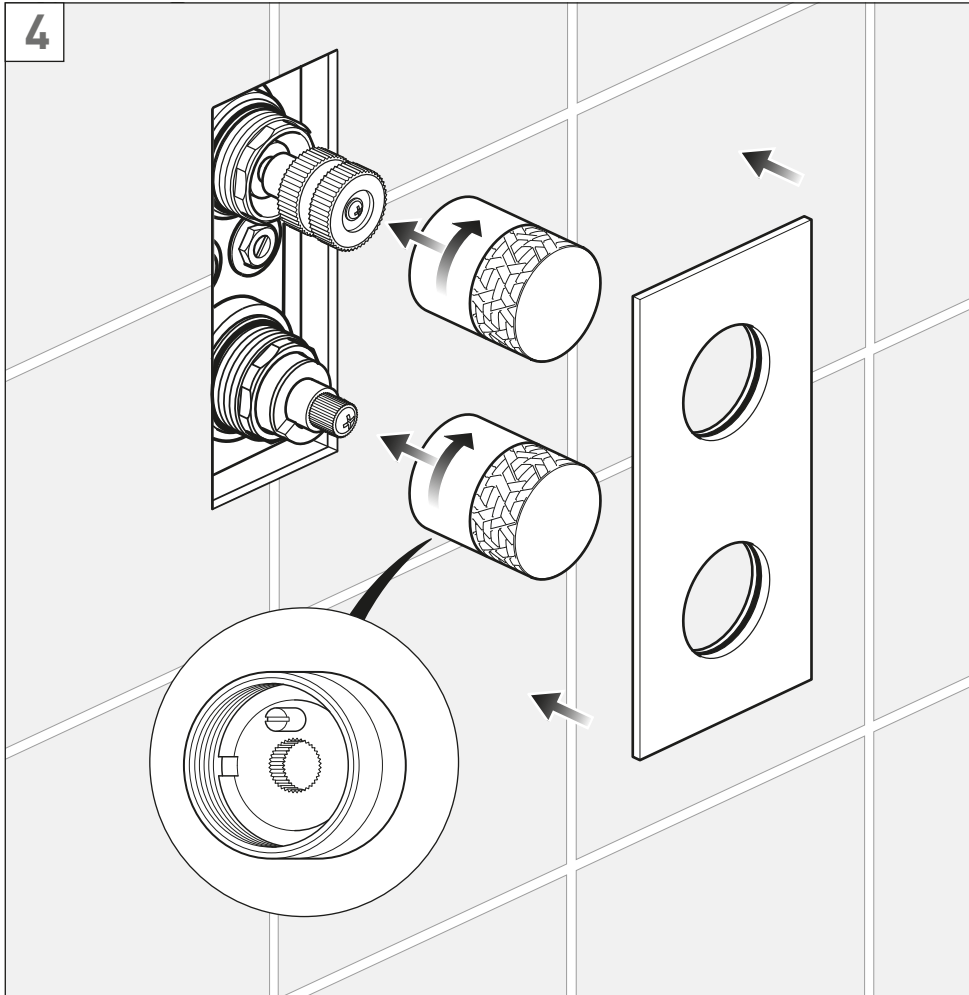

Installation

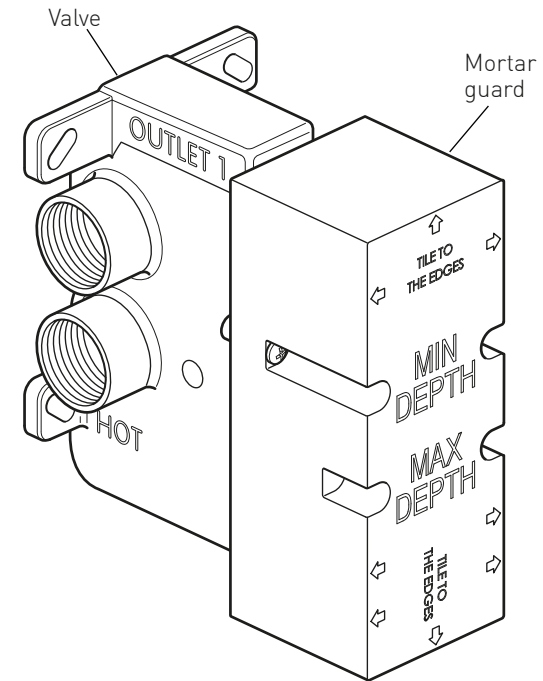

Rinse pipe work thoroughly before fitting the valve.

⚠ Warning! Please check for any hidden cables and pipes before drilling holes in the wall.

The valve must be set into the wall between (75mm minimum – 100mm maximum) If you are fitting the valve to a partition wall or a wall of particularly soft substrate you will need specialist fixings.

Mortar guard

During and after installation protect the outer parts by leaving the mortar guard on the valve to avoid damage to plated surfaces.

Installation

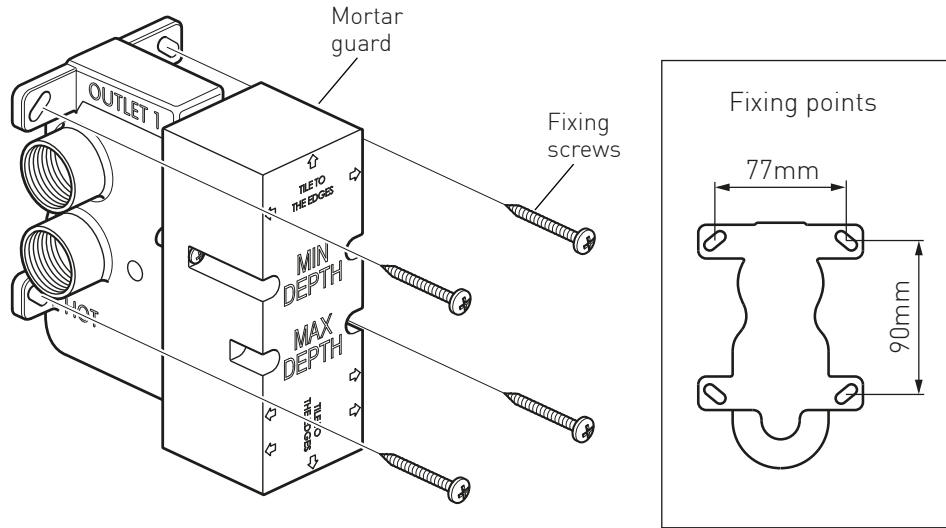

Select the position for the shower valve and offer the shower valve to the wall, make sure the valve is vertical with a level and mark the 4 fixing points with a suitable pencil, see above right for dimensions. Remove the shower valve from the wall, drill the holes to a suitable depth for the wall plugs and secure with suitable screws.

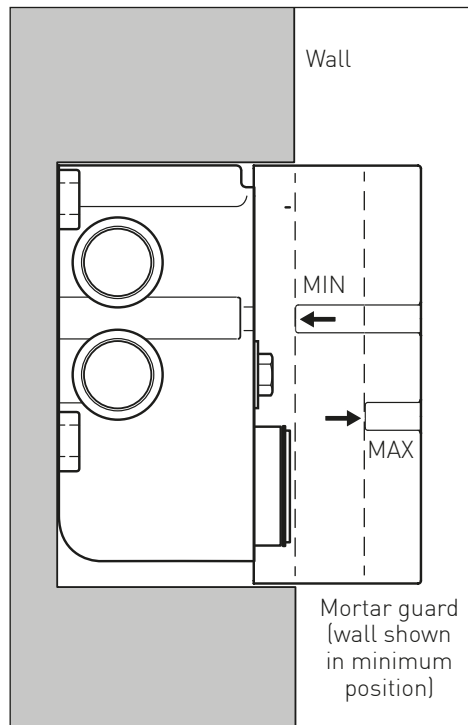

Installation

Connect hot supply to the lower left inlet of the valve and cold supply to the lower right inlet. Connect the outlet to the desired channel e.g. outlet 1 to the shower head and outlet 2 to the handset.

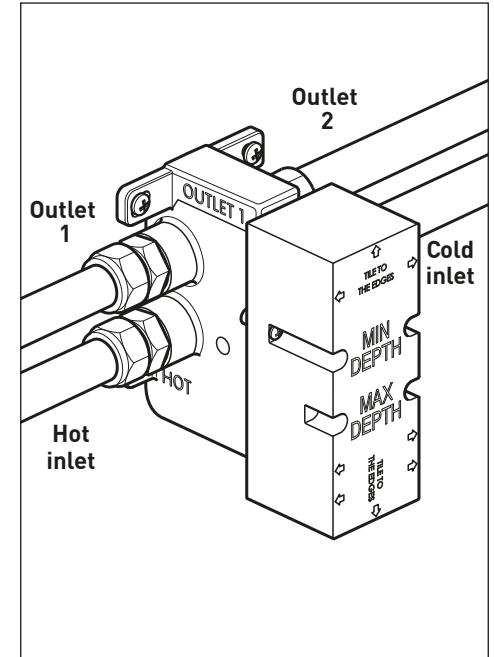

Finish the wall by tiling up to the mortar guard, keep the final finished wall surface between the min and max marks.

Unscrew the 2 mortar guard screws and remove from the wall.

Your valve is now ready to be commissioned. Please refer to page 11 to ensure your valve is calibrated.

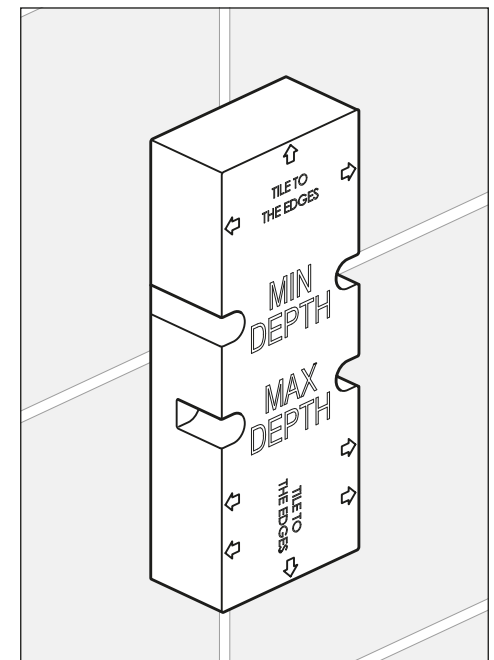

Installation

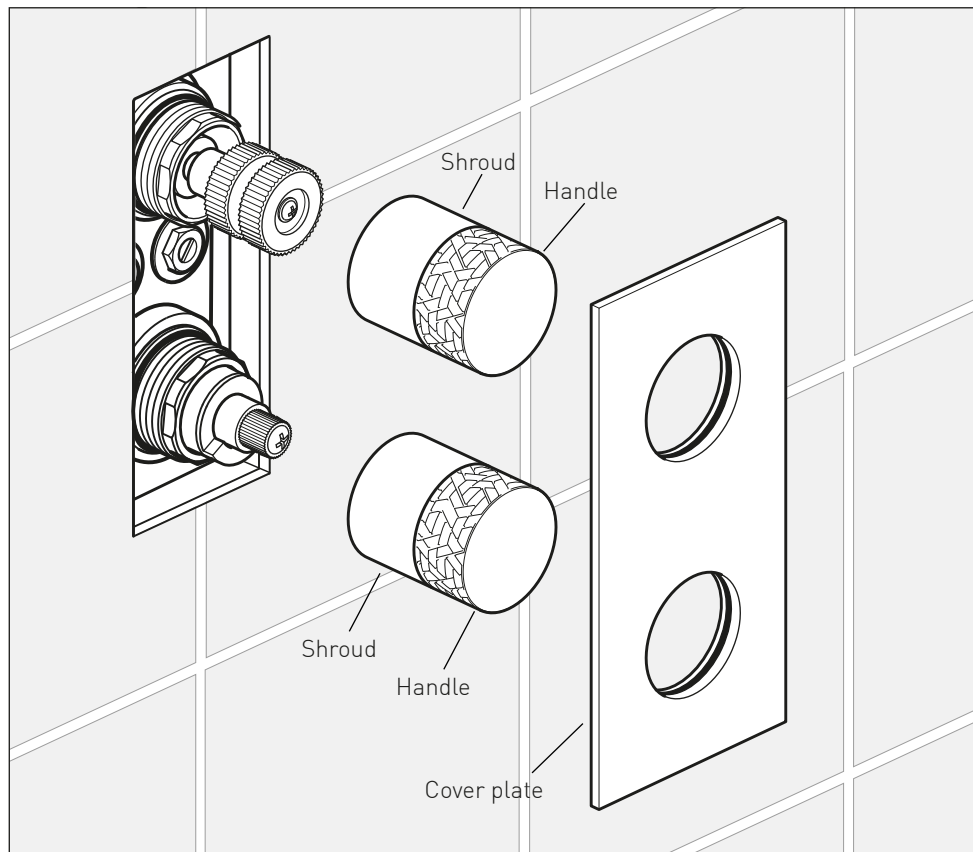

Temperature handle (bottom)

Ensure the temperature handle is correctly located with the handle stop at 12 o'clock. Carefully slide the handle onto the splines of the valve and then screw the shroud part to the valve whilst holding the handle part.

Flow handle (top)

Carefully slide the handle onto the splines of the valve and then screw the shroud part of the handle to the valve whilst holding the handle part.

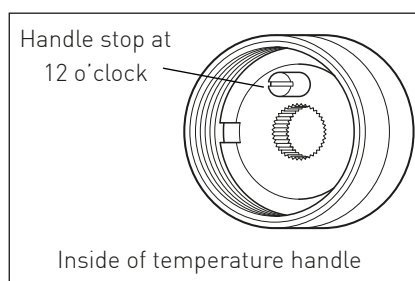

Guide the cover plate over the shrouds and up to the wall being careful not to dislodge or damage the seal. Apply a thin bead of silicone around the outside to seal against the tiled surface.

Temperature resetting

The valve has been factory set under balance pressures and hot water supply at 65° C. When your specific operating conditions are significantly different from the above, the temperature of the water may vary from the setting.

When the difference is too great, you can adjust the calibration of the valve to suit individual requirements of the installation:

1. Check the temperature of the water being delivered to the outlet with a thermometer.
2. If the temperature is not 38° proceed to reset the calibration as follows:
Do not remove the plastic stop ring. Turn the spline of the valve clockwise to decrease the temperature and anti-clockwise to increase the temperature until 38° is achieved at outlet.
3. Ensure that the stop on the stop ring is at 10 o'clock.

When the handle is attached (see page 10) ensure the temperature does not exceed 46° when turned entirely anti-clockwise.

Your valve setting is now calibrated.

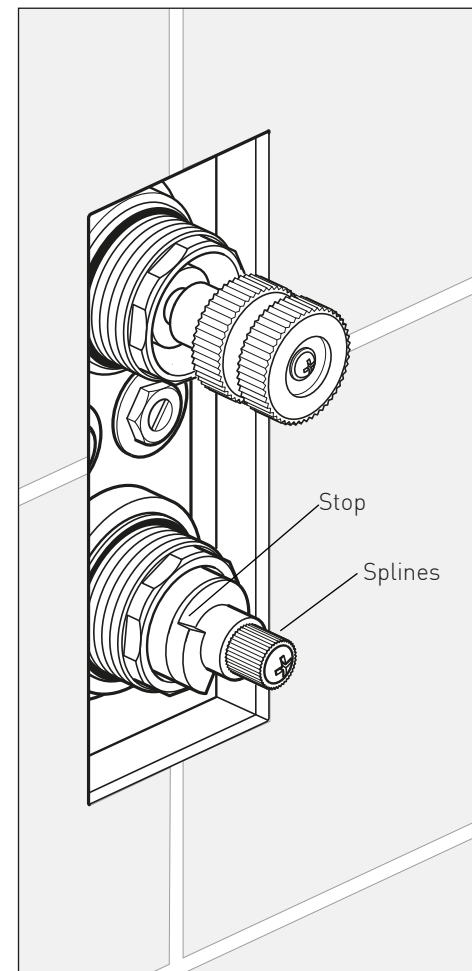

SPECIFICATION SHEET

COLLECTION: OMIKA NOIR

PRODUCT CODE: IND-T148/2-H-OMI-PB

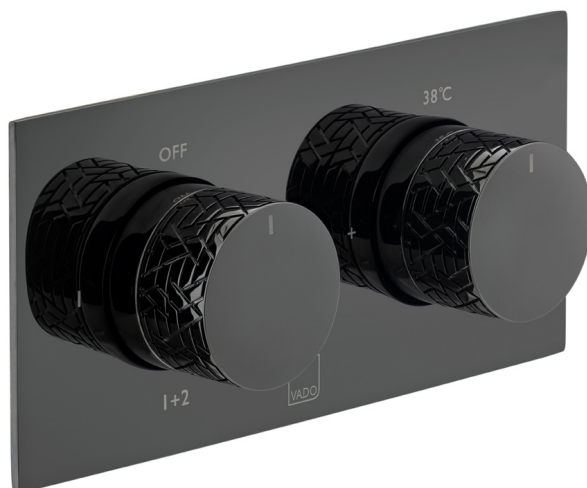

DESCRIPTION:

Tablet Omika horizontal concealed 2 outlet 2 handle thermostatic shower valve with all-flow function wall mounted
thermostatic cartridge V-001C-PLA
diverter cartridge FL-802-33/2MX
2 x 3/4" female inlets
2 x 3/4" female outlets
includes 3/4" - 1/2" adaptors
supplied with mortar/tile guard
min-max wall mount 75-100mm
optimum installation depth 87mm
minimum operating pressure
0.2 bar LP (shower) 1.0 bar MP (bath)

FINISH:

Polished Black

MINIMUM OPERATING PRESSURE:

0.2 bar LP (shower) 1.0 bar MP (bath)

FLOW RATE AT 3.0 BAR FLOW PRESSURE:

outlet 1 29.6 outlet 2 29.7 both 31.9 l/min



tel: 01934 744466
email: sales@vado.com
www.vado.com

where inspiration flows
taps | showering | accessories



TECHNICAL DRAWING

COLLECTION: OMIKA NOIR

PRODUCT CODE: IND-T148/2-H-OMI-PB

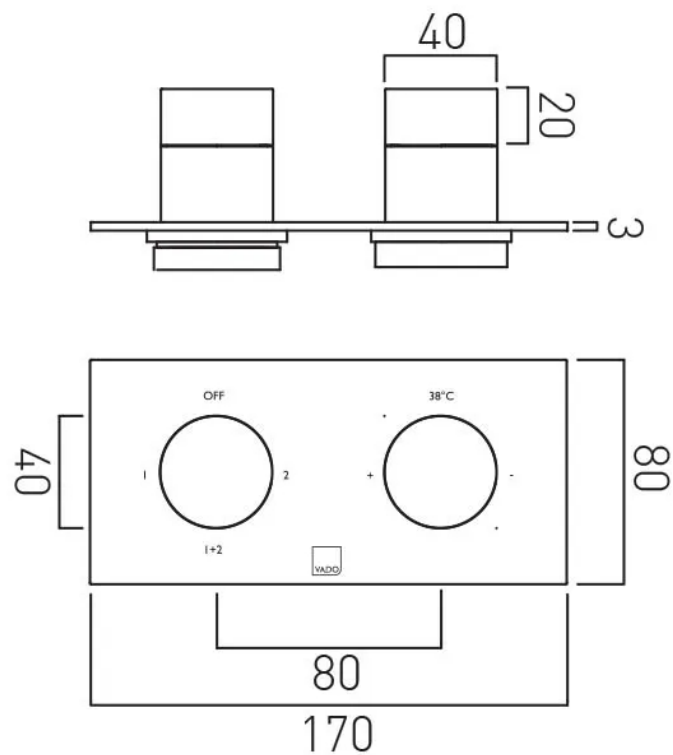

tel: 01934 744466
email: sales@vado.com
www.vado.com

where inspiration flows
taps | showering | accessories



Guarantee

All VADO products come with a 2 year guarantee as standard. Within this guarantee period VADO will provide replacement parts and any labour **[SEE NOTE 1]** needed to complete the product repair.

This standard guarantee may be extended by registering your product to give the following guarantee periods, once registered:

Brassware products from the Individual by VADO collection have a 15 year guarantee (2 years parts and labour plus 13 years parts only).

VADO Sensori SmartTouch and SmartDial products have a 5 year guarantee (parts and labour). VADO Identity and i-tech products have a 5 year guarantee (2 year parts and labour plus 3 years parts only).

All other VADO products have a 3 year guarantee (2 years parts and labour plus 1 year parts only)

[SEE NOTE 2].

Guarantee Conditions

Our products are guaranteed against manufacturing defects from the date of purchase until the expiry of the relevant guarantee period shown above.

The guarantee is only valid if:

- The product has been installed, used and maintained in accordance with VADO's instructions and subjected to normal use only.
- The defect is not due to use of an unsuitable or inadequate water or power supply.
- The defect is not due to accident, misuse, neglect or incorrect/inappropriate repair (other than by VADO or VADO authorised agents) or damage caused by foreign objects or substances.
- The extended guarantee is only available if you have completed the Guarantee Registration Process.

This can be done via the VADO website or via phone to our aftersales team.

Registration must be completed within 6 months from date of purchase.

Under the extended guarantee period VADO will, at its option, offer to supply any replacement product (or component part) assessed to be defective **[SEE NOTE 3]**.

The guarantee (whether standard or extended) is non-transferable to any subsequent owner.

All claims under the guarantee should be notified in the first instance to our Aftersales department, contact details below, this must be done no later than the last day of the relevant guarantee period.

All claims must be accompanied by proof of purchase (sales receipt or delivery note) from an official VADO dealer.

The guarantee does not extend to any consequential loss or damage.

After repair or replacement, the relevant guarantee period will be calculated from the original date of purchase.

VADO operates a policy of continuous product development and therefore reserves the right to change the product, packaging and documentation specifications without notice. E&OE.

NOTES:

[1] Labour via our engineer network is only available in the UK. Attendance by a VADO engineer or sub-contract engineer will be under our standard terms and conditions.

[2] VADO spare parts and shower hoses are under a parts only guarantee.

[3] VADO reserves the right to charge in advance for a product (or replacement part) pending collection and investigation (at VADO expense) to confirm a defect is due to a manufacturing issue.

If a defect is found the charge will be refunded or cancelled.

This guarantee is in addition to and does not affect your statutory rights as a consumer.

Tel: 01934 745163

Email: aftersales@vado.com

KEEP FOR
FUTURE REFERENCE

15
year guarantee

OMIKA *NOIR*

—
2 WAY THERMOSTATIC SHOWER VALVE
USER GUIDE



INDIVIDUAL

by VADO

Welcome

Thank you for selecting Individual by VADO.

Each timeless finish has been tailored to inspire your individual style, ready for you to create a contemporary look that will stand the test of time.

Coupled with our leading 15 year guarantee, this premium product has passed through stringent quality assurance processes to allow you to complete your look with confidence.

Our outstanding customer service, large scale development support and prestigious project history has ensured a globally trusted reputation. For any technical or operation queries, please contact our experienced Aftersales team on 01934 745 163.

Cleaning instructions:

The physical vapor deposition coating on this product is finished to the highest standard. Due care needs to be taken to ensure the appearance is retained. We recommend cleaning all products with a soft damp cloth **ONLY** and advise strongly against the use of all aggressive/corrosive cleaning products i.e. powders and liquids. If these instructions are not followed, this may invalidate your guarantee in the event of a problem occurring.

VADO, Wedmore Road, Cheddar, Somerset, England BS27 3EB
tel 01934 744466 fax 01934 744345
aftersales@vado.com
www.vado.com

Operation - flow control

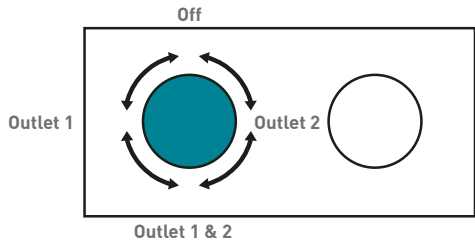
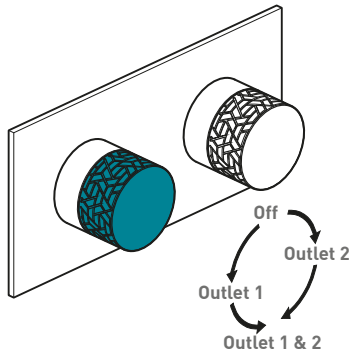

Turning the flow control handle in the direction of the arrow increases the flow of water to the outlet.

Operation - temperature control

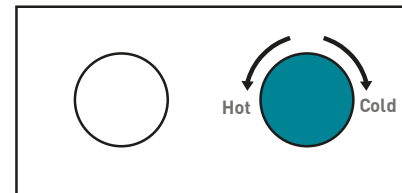
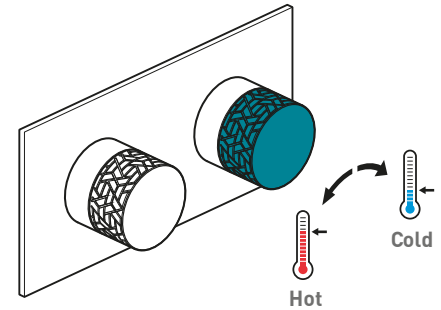

Turning the temperature control handle in the direction of the arrows increases/decreases the temperature

Parts list:

Item	Code	Quantity
1	FL-802-33/2MX	1
2	V-704-34S	1
3	TAB-003A-FIL	1
4	TAB-003A-FIL-HOUSING	1
5	TAB-STOPRING	1
6	TAB-NUT/TEMP-BRA	1
7	TAB-NUT/FLOW-BRA	1
8	TAB-DIV/EXTSPLINE-BR	1
9	TAB-COG-BRA	1
10	TAB-DIV/COVERNUT-BRA	1
11	CEL-CON-3/4MX1/2F-BR	1
12	INSTALLATION GUIDE & USER MANUAL	1

Parts:

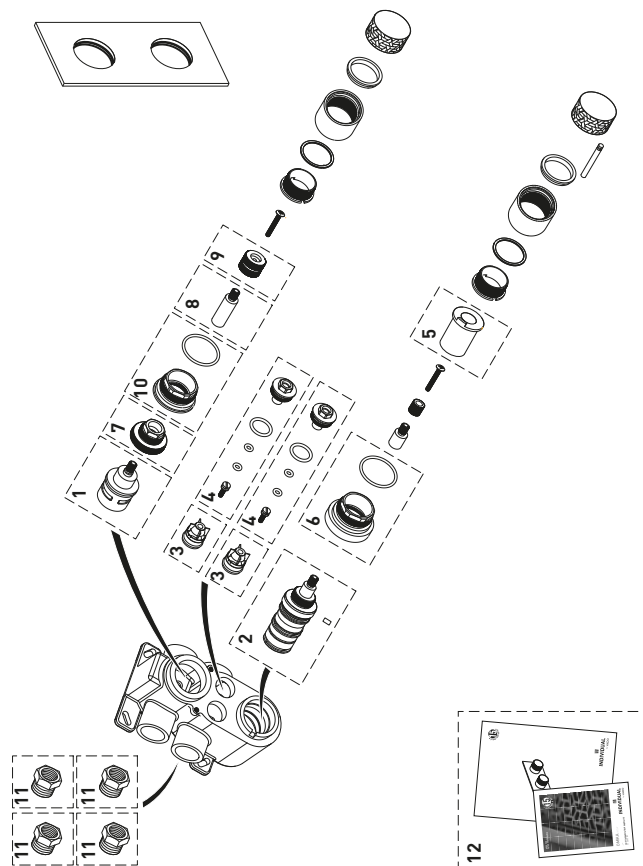



INDIVIDUAL
by VADO

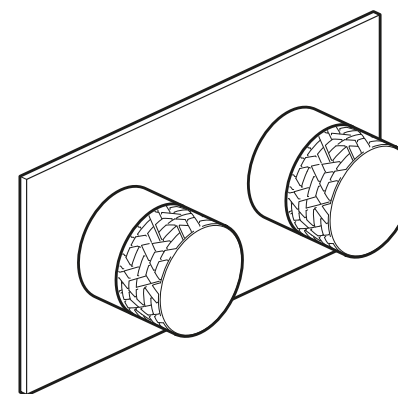

OMIKA NOIR

2 way thermostatic shower valve

—

INSTALLATION GUIDE

VADO
Wedmore Road, Cheddar,
Somerset, England BS27 3EB
tel 01934 744466
fax 01934 744345
www.vado.com
sales@vado.com

Version 1, 1-7-21

INDIVIDUAL
by VADO

Important - please read

Please read these instructions carefully before starting installation and keep for future reference.

Remove all packaging and check the product for missing parts or damage before starting installation.

Any alterations made to this product and fittings may infringe water regulations and will invalidate the guarantee.

The installation must comply with all Local/National Water Supply Authority Regulations/Byelaws and Building and Plumbing Regulations.

To be installed in accordance with BS EN806.

We strongly recommend that you use a qualified and registered plumber.

General installation

This fitting is a mixing device and therefore water supplies should be reasonably balanced.

When installed, the fitting must comply with the requirements of the Water Supply (Water Fittings) Regulations 1999 and Scottish Byelaws 2004.

For further information, contact the Water Regulations department of your local water supplier (see the WRAS website www.wras.co.uk for details) or the Water Regulations Advisory Scheme by email (info@wras.co.uk) or telephone: 01495848454.

Before making any inlet pipe connections, all supply pipes MUST be thoroughly flushed to remove debris. Failure to do so could result in damage or low flow from the mixer unit.

The fitting of isolating valves to the inlet feeds is advised for ease of maintenance.

Please take great care when installing this mixer not to damage its surface.

Please note if installing in an enclosed environment, access should be left for servicing and maintenance. No costs relating to inadequate access can be accepted.

Operating Specifications

Operating Pressure

Minimum operating pressure **0.2 bar** (**1 bar** if used as a bath fill)

Maximum operating pressure **5 bar**

Contents of Packaging



Installation guide &
User manual

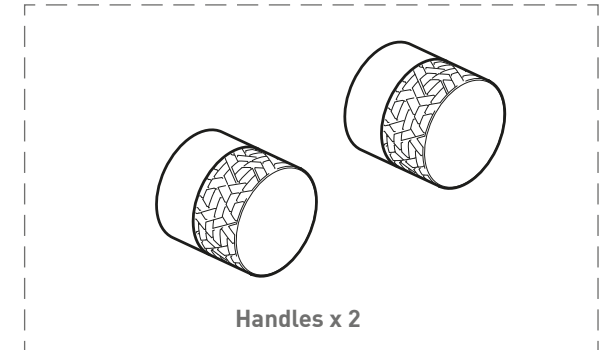

Handles x 2

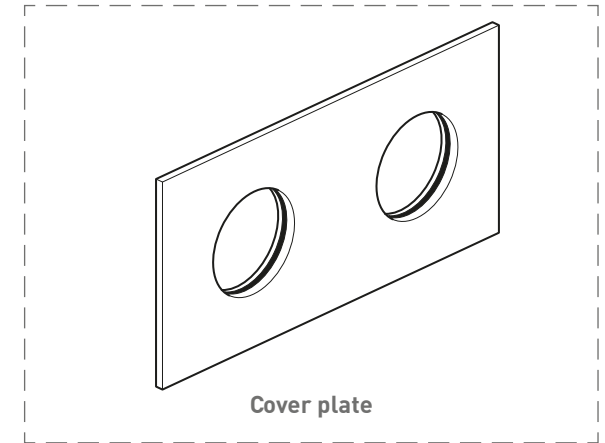

Cover plate

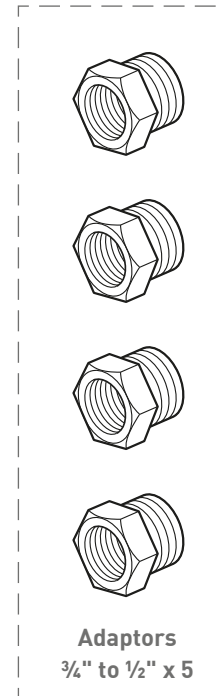

Adaptors
3/4" to 1/2" x 5

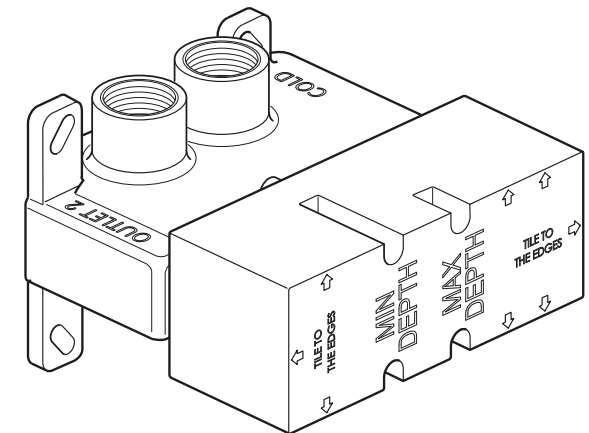

Valve with
Mortar guide

Dimensions

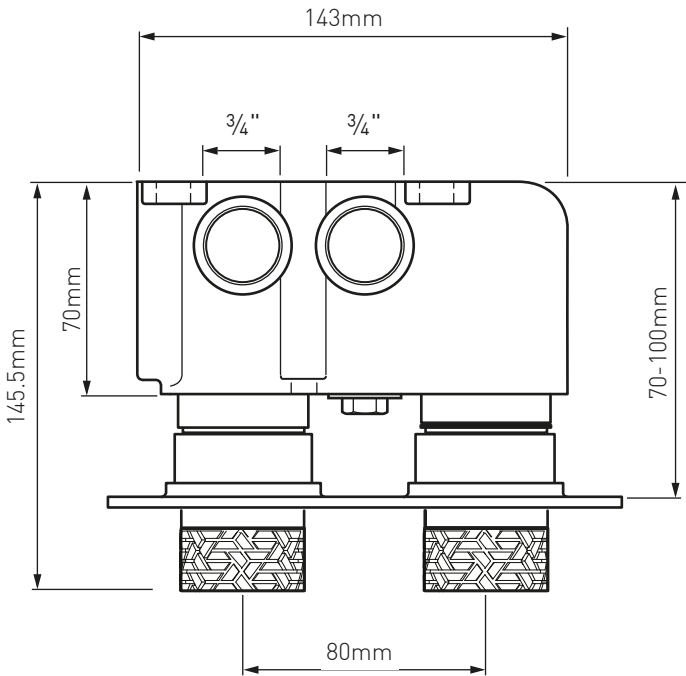

Installation - Quick guide

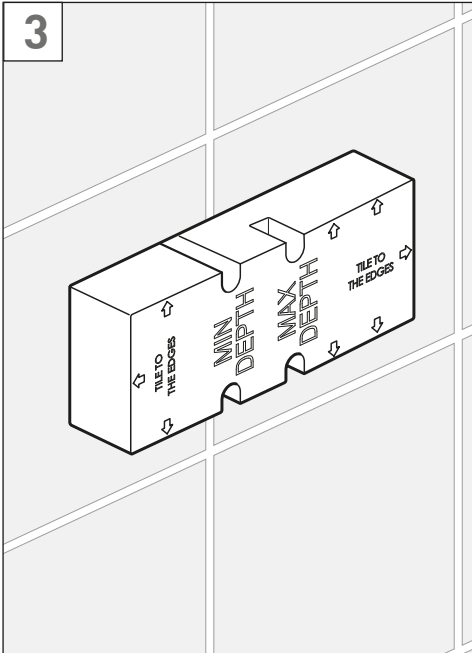
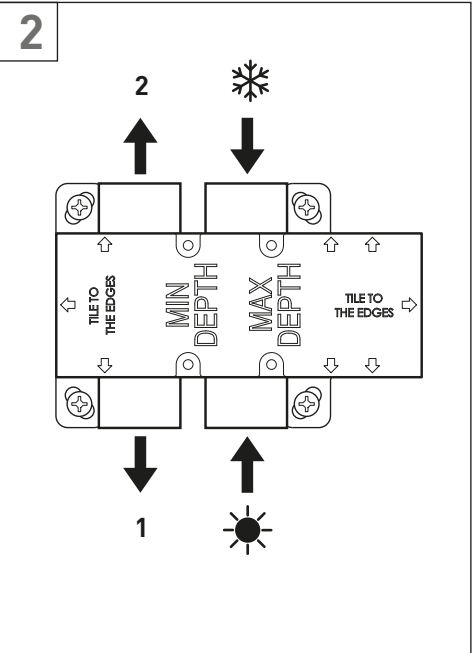
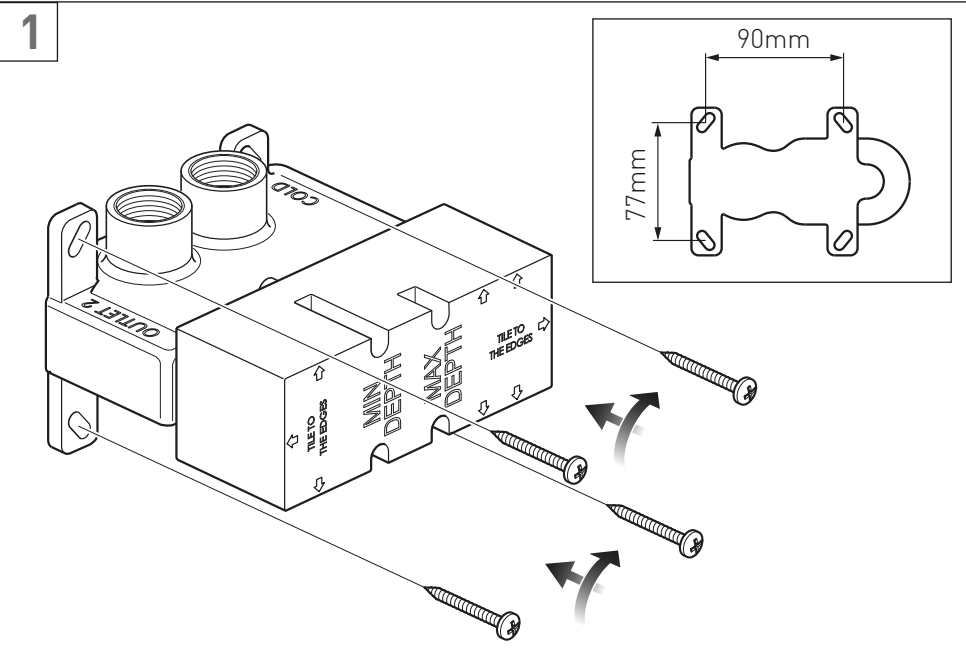

Installation - Quick guide

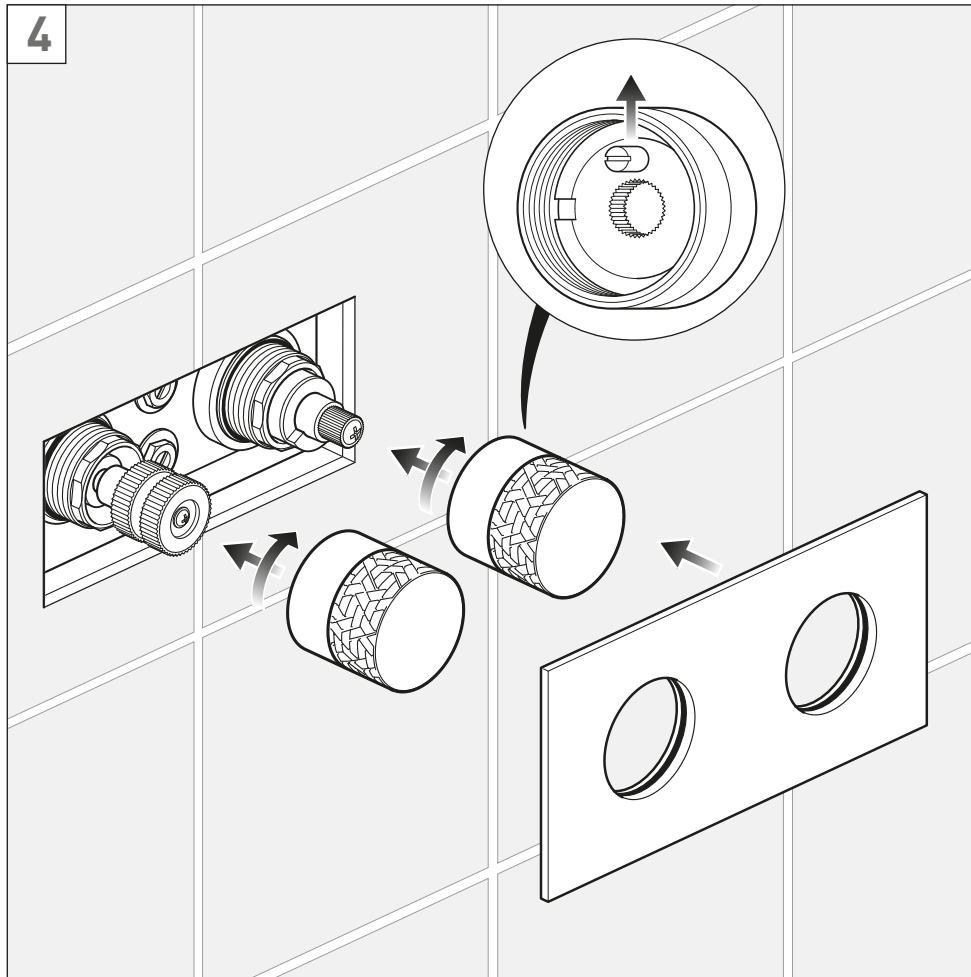

Installation

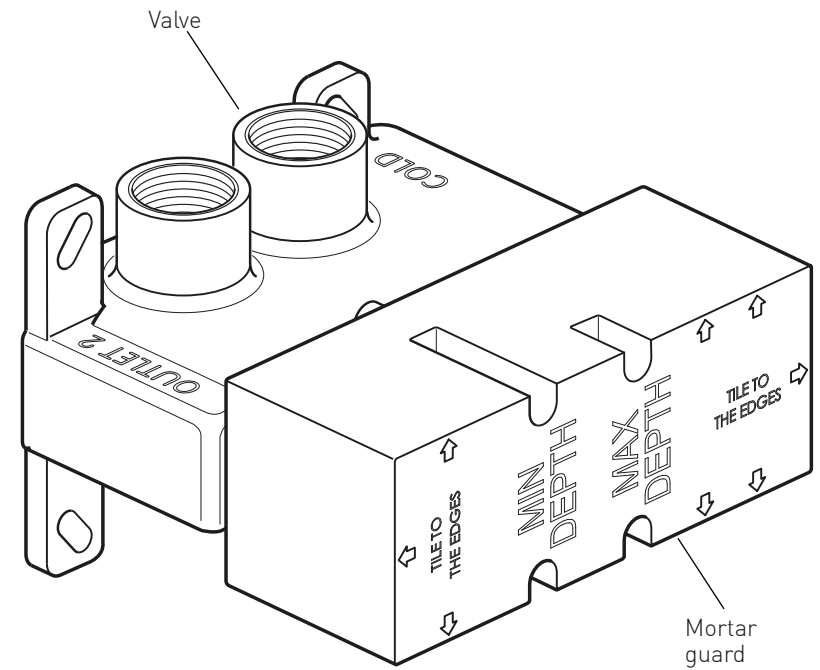

Rinse pipe work thoroughly before fitting the valve.

⚠ Warning! Please check for any hidden cables and pipes before drilling holes in the wall.

The valve must be set into the wall between (75mm minimum – 100mm maximum) If you are fitting the valve to a partition wall or a wall of particularly soft substrate you will need specialist fixings.

Mortar guard

During and after installation protect the outer parts by leaving the mortar guard on the valve to avoid damage to plated surfaces.

Installation

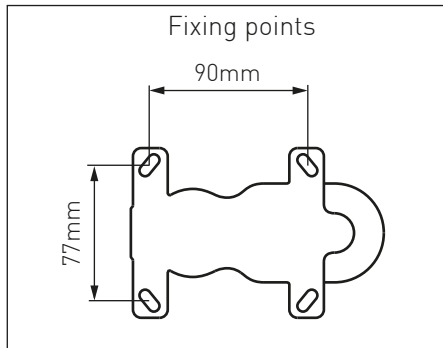
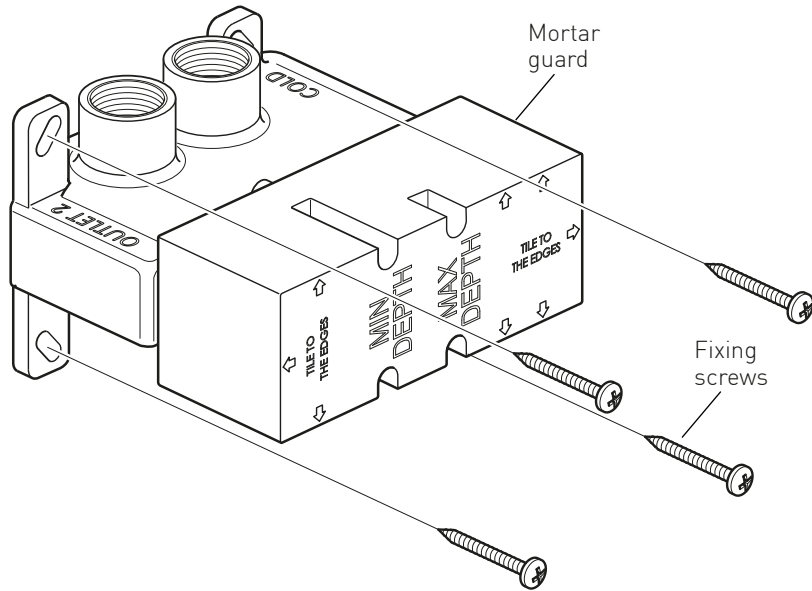

Select the position for the shower valve and offer the shower valve to the wall, make sure the valve is horizontal with a level and mark the 4 fixing points with a suitable pencil, see above left for dimensions. Remove the shower valve from the wall, drill the holes to a suitable depth for the wall plugs and secure with suitable screws.

Installation

Connect hot supply to the lower right inlet of the valve and cold supply to the upper right inlet. Connect the outlet to the desired channel e.g. outlet 1 to the shower head and outlet 2 to the handset.

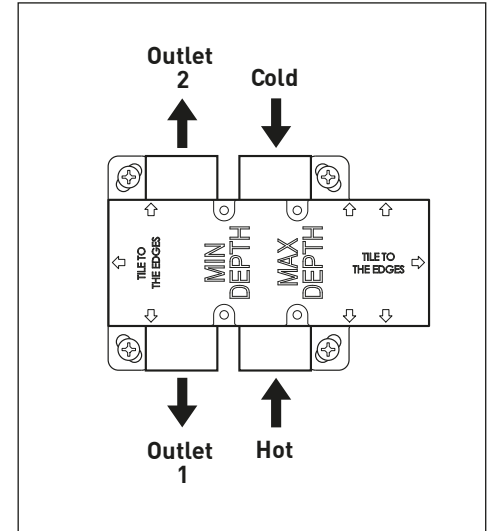

Finish the wall by tiling up to the mortar guard, keep the final finished wall surface between the min and max marks. Unscrew the 2 mortar guard screws and remove from the wall.

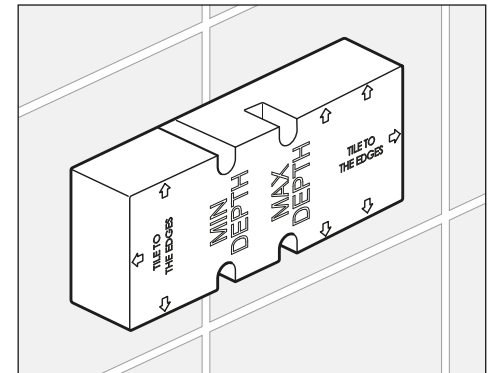

Your valve is now ready to be calibrated. Please refer to page 11 to ensure your valve is calibrated.

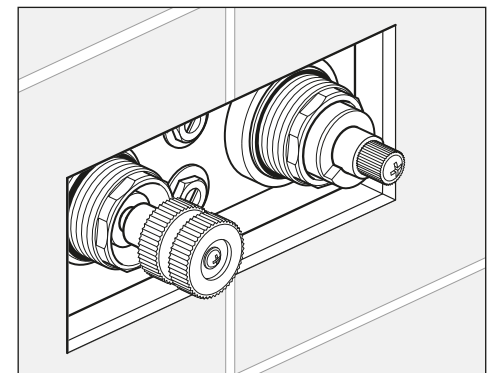

Installation - handles

Temperature handle (right)

Ensure the temperature handle is correctly located with the handle stop at 12 o'clock.

Carefully slide the handle onto the splines of the valve and then screw the shroud part to the valve whilst holding the handle part.

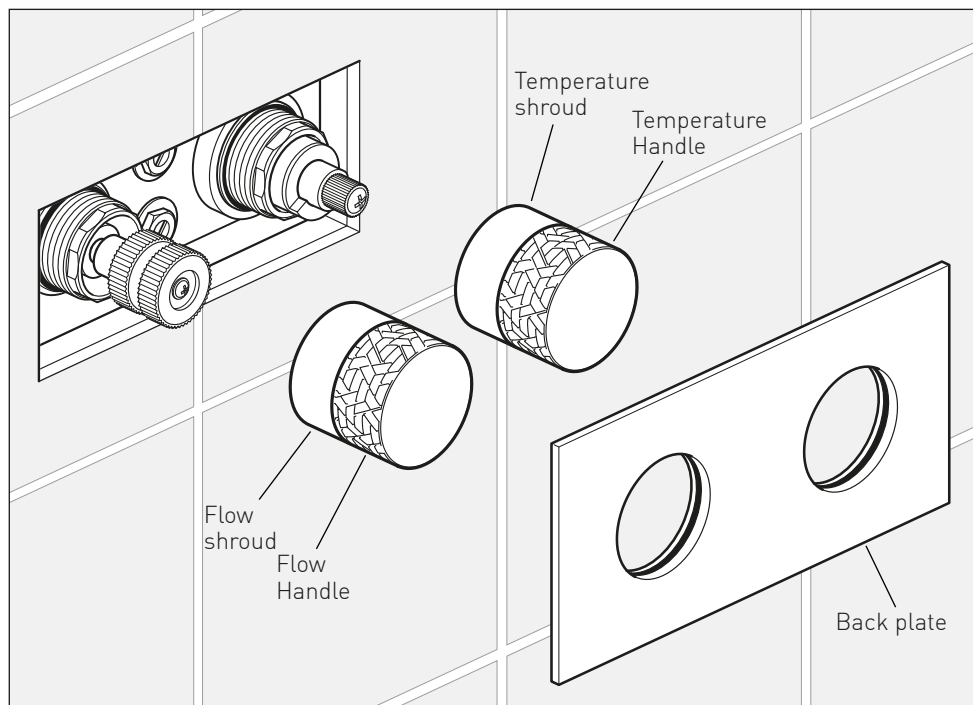
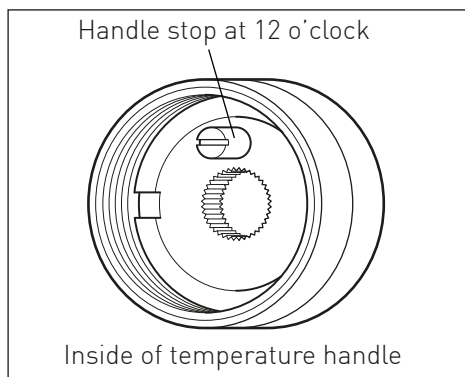

Flow handle (left)

Carefully slide the handle onto the splines of the valve and then screw the shroud part of the handle to the valve whilst holding the handle part.

Back plate

Slide the back plate over the valve being careful not to dislodge or damage the seals. Push the back plate up to the wall, apply a thin bead of silicone around the outside to seal against the tiled surface.

Temperature resetting

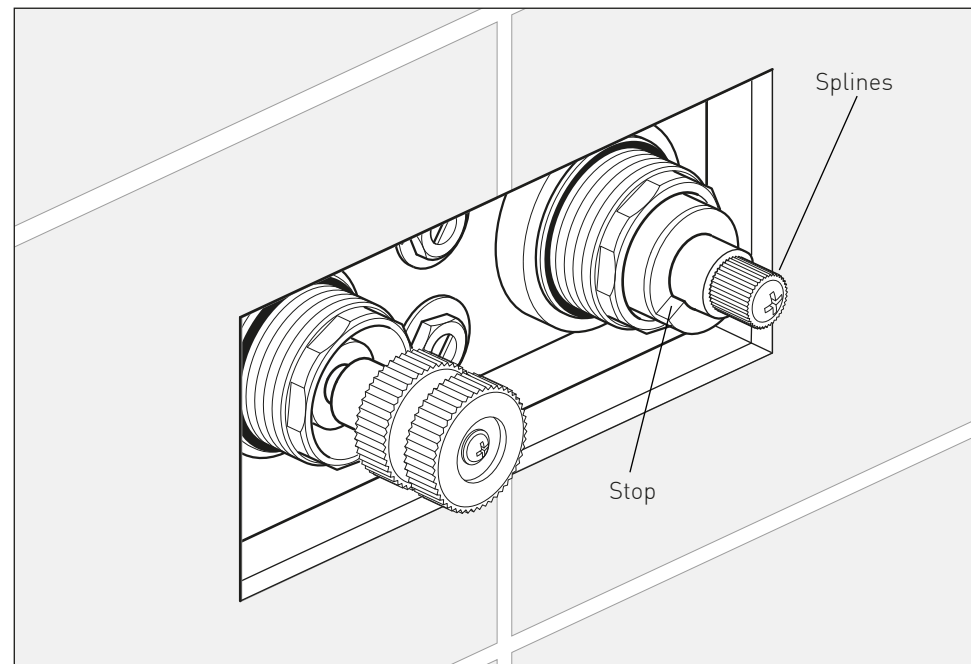

The valve has been factory set under balance pressures and hot water supply at 65° C. When your specific operating conditions are significantly different from the above, the temperature of the water may vary from the setting.

When the difference is too great, you can adjust the calibration of the valve to suit individual requirements of the installation:

1. Check the temperature of the water being delivered to the outlet with a thermometer.
2. If the temperature is not 38° proceed to reset the calibration as follows:
Do not remove the plastic stop ring. Turn the spline of the valve clockwise to decrease the temperature and anti-clockwise to increase the temperature until 38° is achieved at outlet.
3. Ensure that the stop on the stop ring is at 8 o'clock.

When the handle is attached (see page 10) ensure the temperature does not exceed 46° when turned entirely anti-clockwise.

Your valve setting is now calibrated.