

SPECIFICATION SHEET

COLLECTION: AXBRIDGE

PRODUCT CODE: BC-AXB-233-CP

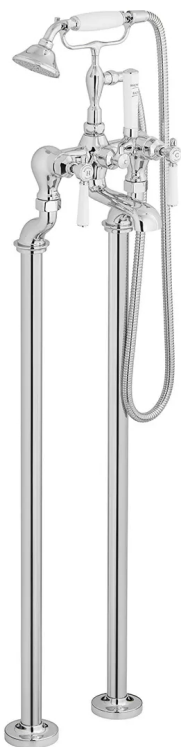

DESCRIPTION:

Axbridge
exposed bath shower mixer
floor mounted
with shower kit
lever handles
with water flow straightener
cold ceramic cartridge FL-511-RTC tbc
hot ceramic cartridge FL-511-LTC
2 x 1/2" female inlets
minimum operating pressure 1.0 bar MP

FINISH:

Chrome

MINIMUM OPERATING PRESSURE:

1.0 bar MP

FLOW RATE AT 3.0 BAR FLOW PRESSURE:

41 l/min (bath fill) 21 l/min (shower)

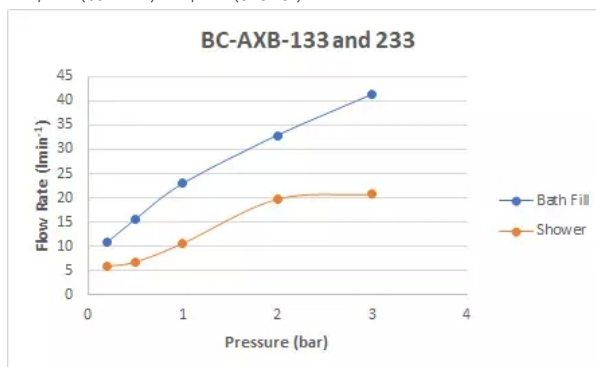

BOOTH & Co.
ENGLAND

Timeless Design. Pioneering Performance.

Your journey to distinction awaits.

01934 744466 | sales@vado.com | www.vado.com/booth-and-co

TECHNICAL DRAWING

COLLECTION: AXBRIDGE

PRODUCT CODE: BC-AXB-233-CP

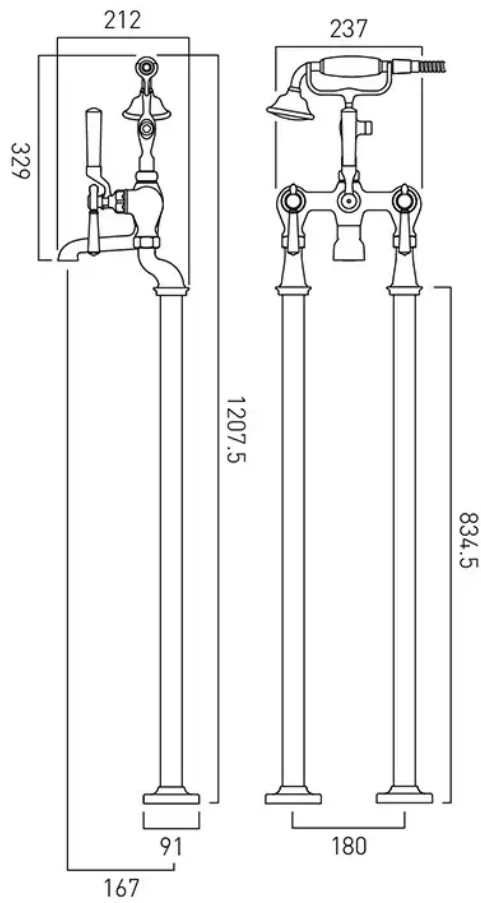

Guarantee

All VADO and Booth & Co. products come with a 2 year guarantee as standard. Within this guarantee period VADO will provide replacement parts and any labour **[SEE NOTE 1]** needed to complete the product repair.

This standard guarantee may be extended by registering your product to give up to a 15 year guarantee period. Once registered:

VADO chromed brassware and stainless steel products have a 12 year guarantee (2 years parts and labour plus 10 years parts only).

Individual by VADO and Booth & Co. products have a 15 year guarantee (2 years parts plus 13 years parts only) *with the exception of Sensori products (please see details of guarantee below).*

VADO Sensori Smart Touch and Smart Dial products have a 5 year guarantee (parts and labour).

VADO Identity and i-tech products have a 5 year guarantee (2 year parts and labour plus 3 years parts only).

All other VADO products have a 3 year guarantee (2 years parts and labour plus 1 year parts only) **[SEE NOTE 2].**

VADO electric showers have a 2 years parts and labour guarantee.

Guarantee conditions

Our products are guaranteed against manufacturing defects from the date of purchase until the expiry of the relevant guarantee period shown above.

The guarantee is only valid if:

- The product has been installed, used and maintained in accordance with VADO's instructions and subjected to normal use only.
- The defect is not due to use of an unsuitable or inadequate water or power supply.
- The defect is not due to accident, misuse, neglect or incorrect/inappropriate repair (other than by VADO or VADO authorised agents) or damage caused by foreign objects or substances.
- The extended guarantee is only available if you have completed the Guarantee Registration Process.

This can be done via the VADO website or via phone to our aftersales team. Registration must be completed within 6 months from date of purchase.

Under the extended guarantee period VADO will, at its option, offer to supply any replacement product (or component part) assessed to be defective **[SEE NOTE 3].**

The guarantee (whether standard or extended) is non-transferable to any subsequent owner. All claims under the guarantee should be notified in the first instance to our Aftersales department, contact details below, this must be done no later than the last day of the relevant guarantee period. All claims must be accompanied by proof of purchase (sales receipt or delivery note) from an official VADO dealer.

The guarantee does not extend to any consequential loss or damage.

After repair or replacement, the relevant guarantee period will be calculated from the original date of purchase.

VADO operates a policy of continuous product development and therefore reserves the right to change the product, packaging and documentation specifications without notice.

NOTES:

[1] Labour via our engineer network is only available in the UK. Attendance by a VADO engineer or sub-contract engineer will be under our standard terms and conditions.

[2] VADO spare parts and shower hoses are under a parts only guarantee.

[3] VADO reserves the right to charge in advance for a product (or replacement part) pending collection and investigation (at VADO expense) to confirm a defect is due to a manufacturing issue.

If a defect is found the charge will be refunded or cancelled. This guarantee is in addition to and does not affect your statutory rights as a consumer.

Tel: 01934 745163

Email: aftersalescare@vado.com

KEEP FOR
FUTURE REFERENCE

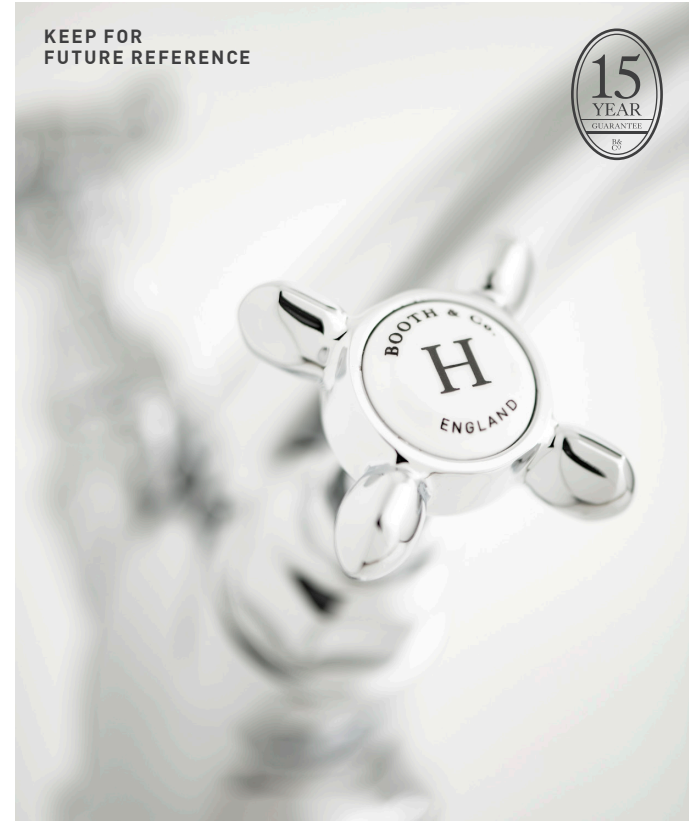

AXBRIDGE

FLOOR MOUNTED MIXER
USER GUIDE

BOOTH & Co.
ENGLAND

Welcome to Booth & Co.

Expertly designed in our home town of Cheddar, Somerset, each Booth & Co. product is as time-honoured on the outside as it is pioneering within.

Hand-crafted to exude a distinct, timeless sophistication, this product has passed through stringent quality assurance processes and demanding lifecycle mechanical testing to ensure an unrivalled quality.

Our leading 15 year guarantee certifies excellence within every detail.

Part of the VADO family, Booth & Co. retains the same outstanding customer service and large scale development support that earned VADO a globally trusted reputation. For any technical or operation queries, please contact our experienced Aftersales team on 01934 745 163.

Indulge in luxury as it should be.

VADO
Wedmore Road, Cheddar,
Somerset, England BS27 3EB
tel 01934 744466
fax 01934 744345
www.vado.com
sales@vado.com

Cleaning instructions:

The electroplating on this product is finished to the highest standard. Due care needs to be taken to ensure the appearance is retained.

We recommend cleaning all products with a soft damp cloth ONLY and advise strongly against the use of all aggressive/corrosive cleaning products i.e. powders and liquids. If these instructions are not followed, this may invalidate your guarantee in the event of a problem occurring.

Operation - cross handles

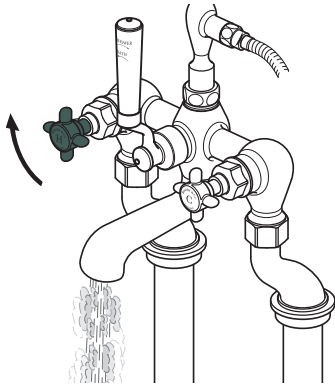

Turning the hot handle clockwise will increase the flow of hot water.

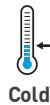
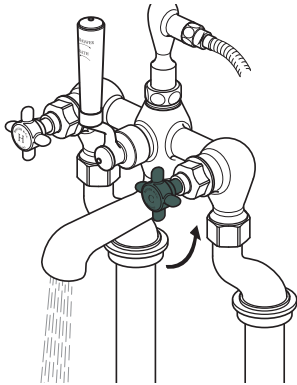

Turning the cold handle anti-clockwise will increase the flow of cold water.

Operation - lever handles

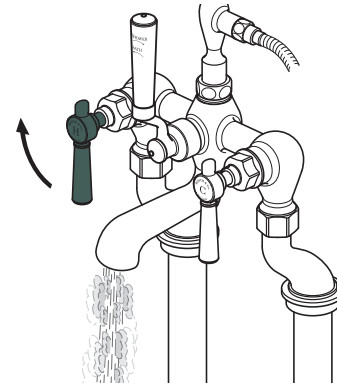

Turning the hot handle clockwise will increase the flow of hot water.

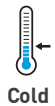
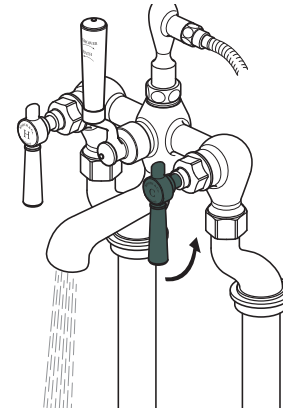

Turning the cold handle anti-clockwise will increase the flow of cold water.

Operation - diverter

Notes:

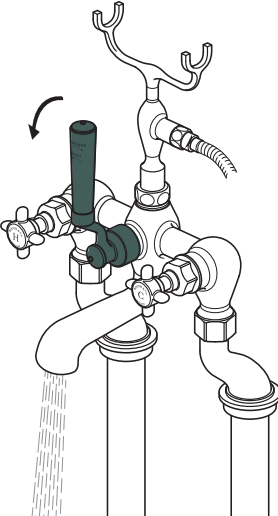

Turning the handle anti-clockwise will divert the flow of water to the spout.

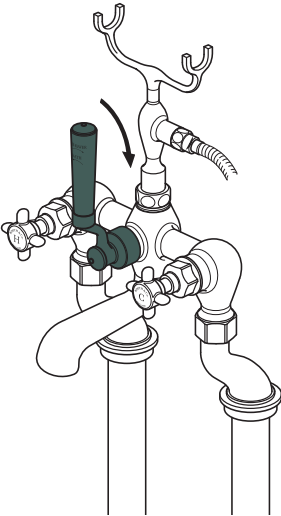

Turning the handle clockwise will divert the flow of water to the Handset



BOOTH & Co.

ENGLAND

This instruction booklet covers model:

- BC-AXB-133-CP
- BC-AXB-133-BN
- BC-AXB-233-CP
- BC-AXB-233-BN

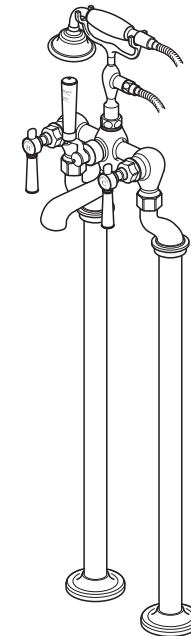
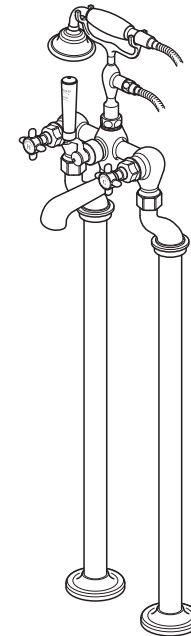

VADO
Wedmore Road, Cheddar,
Somerset, England BS27 3EB
tel 01934 744466
fax 01934 744345
www.vado.com
sales@vado.com

Version 1, 1-5-19

AXBRIDGE

BC-AXB-133-CP, BC-AXB-133-BN
BC-AXB-233-CP, BC-AXB-233-BN
INSTALLATION GUIDE

BOOTH & Co.
ENGLAND

Important - please read

Please read these instructions carefully before starting installation and keep for future reference.

Remove all packaging and check the product for missing parts or damage before starting installation.

Any alterations made to this product and fittings may infringe water regulations and will invalidate the guarantee.

The installation must comply with all Local/National Water Supply Authority Regulations/Byelaws and Building and Plumbing Regulations.

To be installed in accordance with BS EN806.

We strongly recommend that you use a qualified and registered plumber.

General installation

This fitting is a mixing device and therefore water supplies should be reasonably balanced.

When installed, the fitting must comply with the requirements of the Water Supply (Water Fittings) Regulations 1999 and Scottish Byelaws 2004.

For further information, contact the Water Regulations department of your local water supplier (see the WRAS website www.wras.co.uk for details) or the Water Regulations Advisory Scheme by email (info@wras.co.uk) or telephone: 01495848454.

Before making any inlet pipe connections, all supply pipes MUST be thoroughly flushed to remove debris. Failure to do so could result in damage or low flow from the mixer unit. Water Supply (Water Fittings) Regulations 1999 Schedule 2 Section 13.

The fitting of isolating valves to the inlet feeds is advised for ease of maintenance.

Please take great care when installing this mixer not to damage its surface.

Please note if installing in an enclosed environment, access should be left for servicing and maintenance. No costs relating to inadequate access can be accepted.

Operating Specifications

Operating Pressure

Minimum operating pressure 1 bar

Maximum operating pressure 5 bar

Contents of Packaging



Installation guide &
User manual

Cross handle option OR Lever handle option

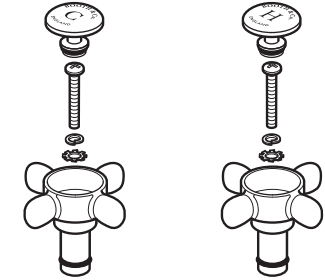

Cross handles with spring washer,
lock washer, screw and screw cover

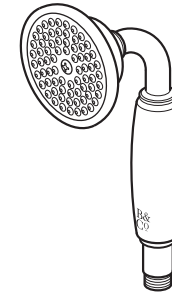

Handset

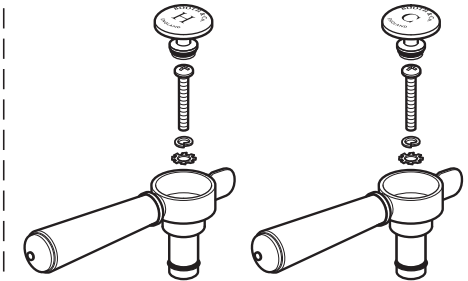

Lever handles with spring washer,
lock washer, screw and screw cover

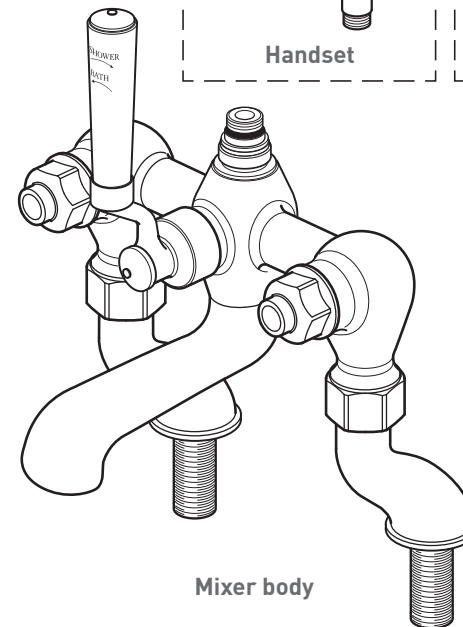

Mixer body

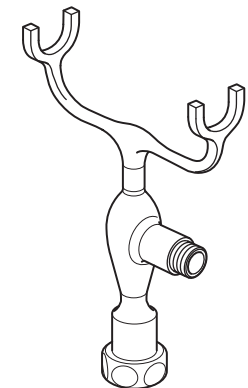

Handset holder

Contents of Packaging

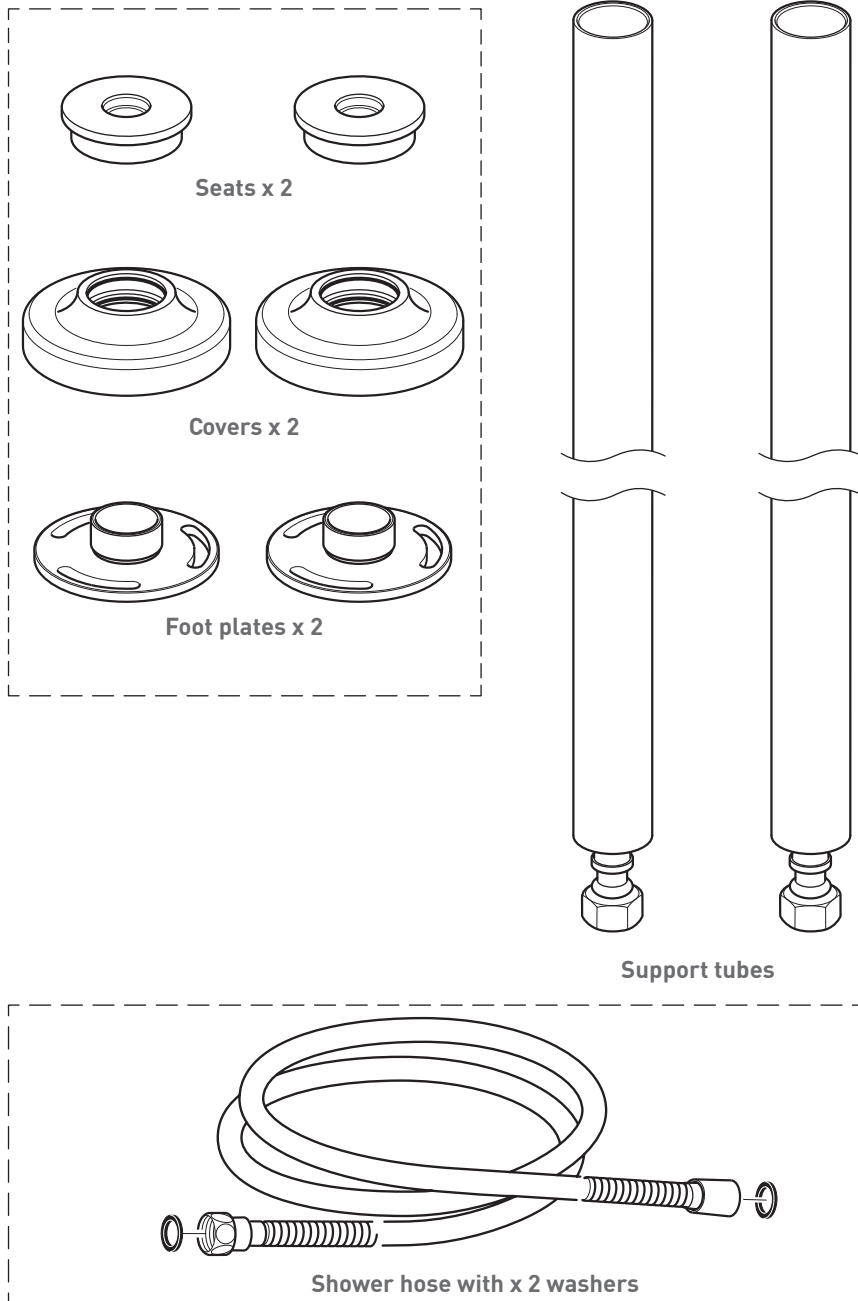

Dimensions - cross handles

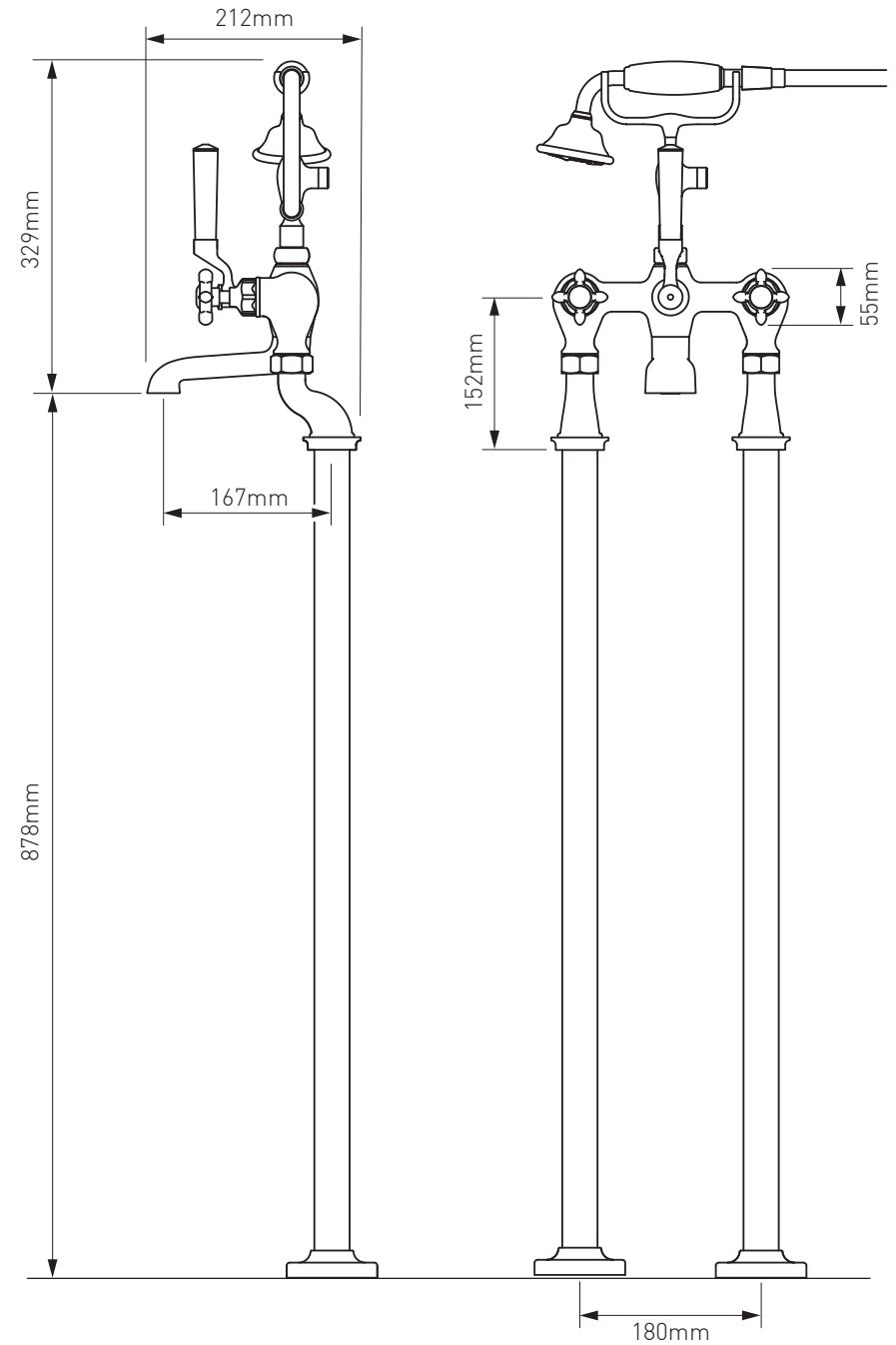

Dimensions - lever handle

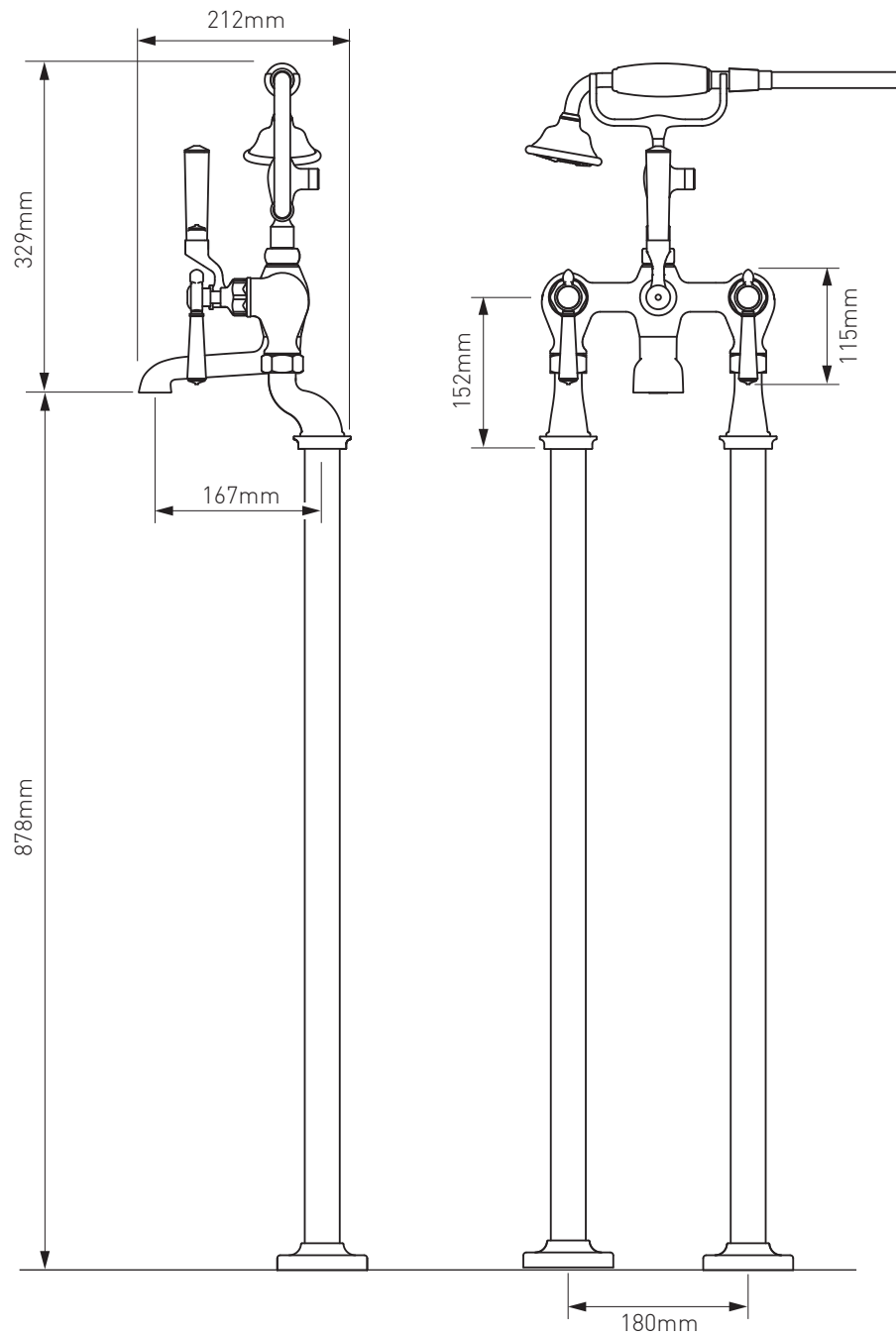

Installation - Quick guide

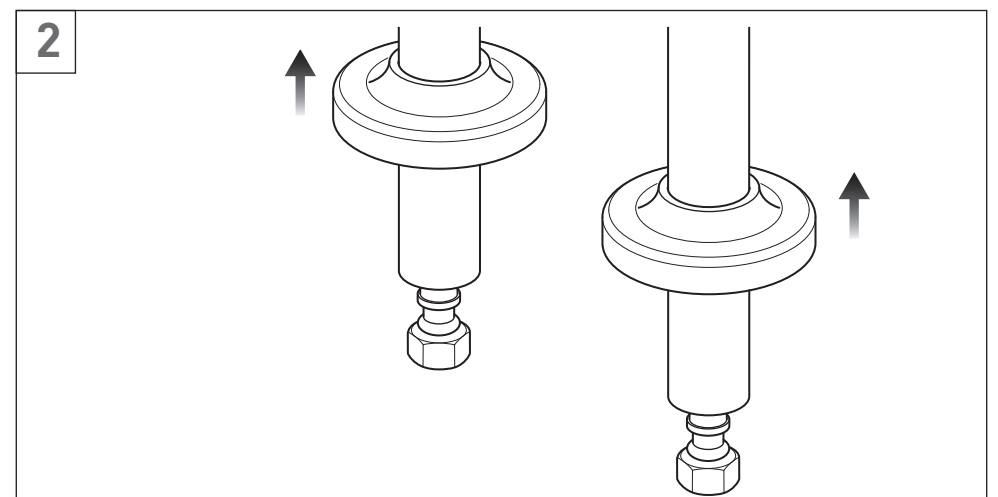
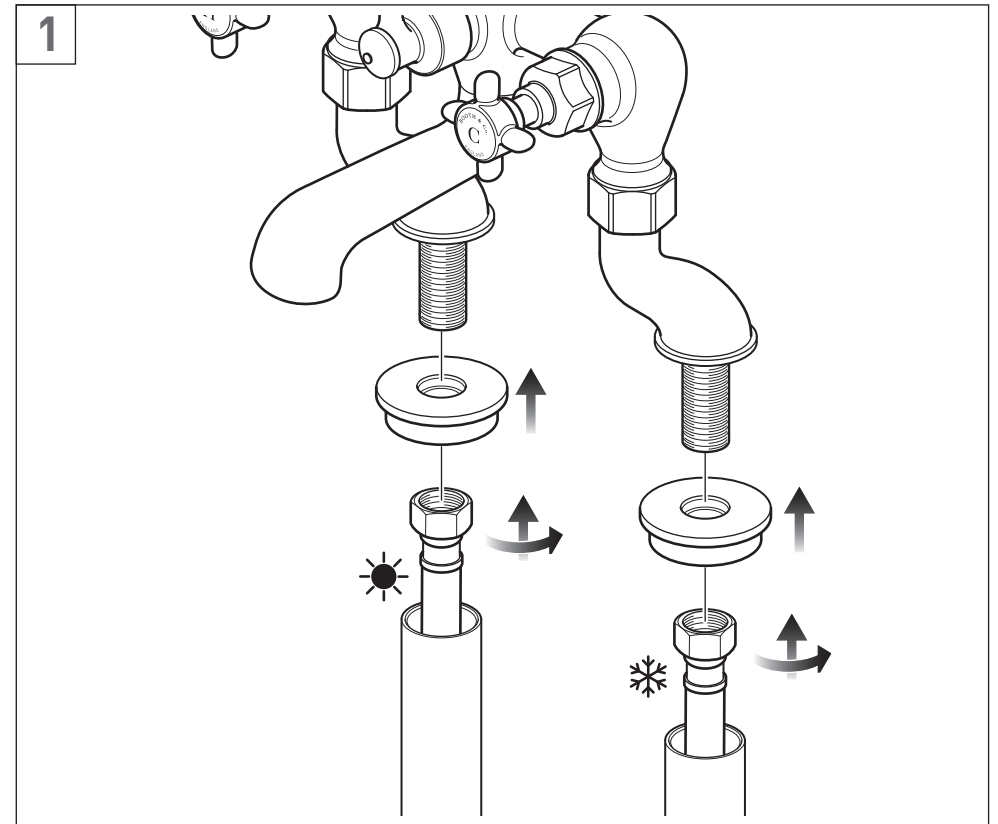

Installation - Quick guide

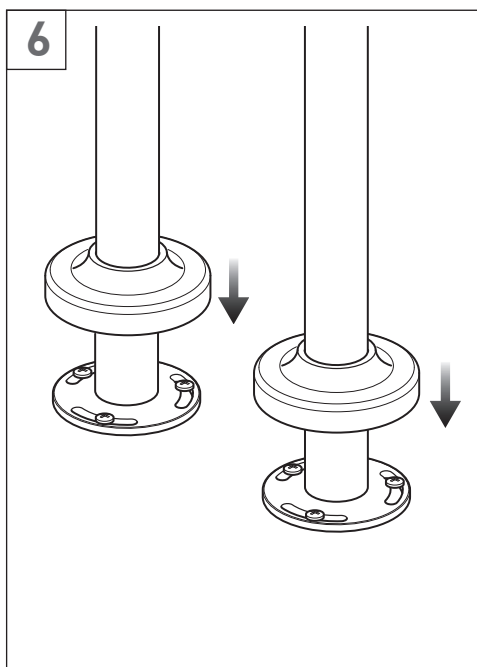
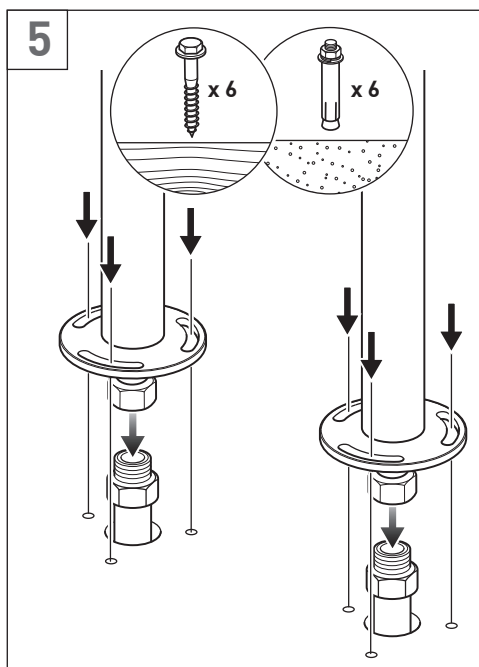
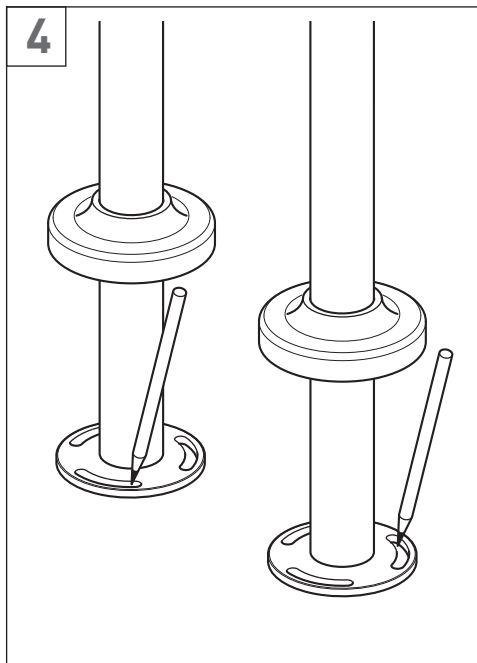
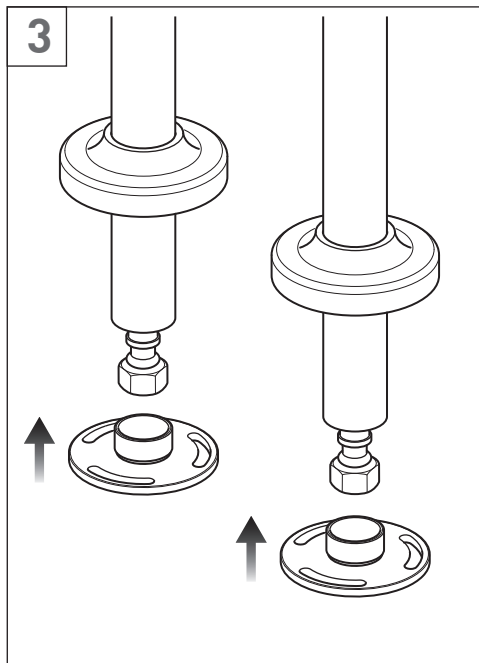

Installation - Quick guide

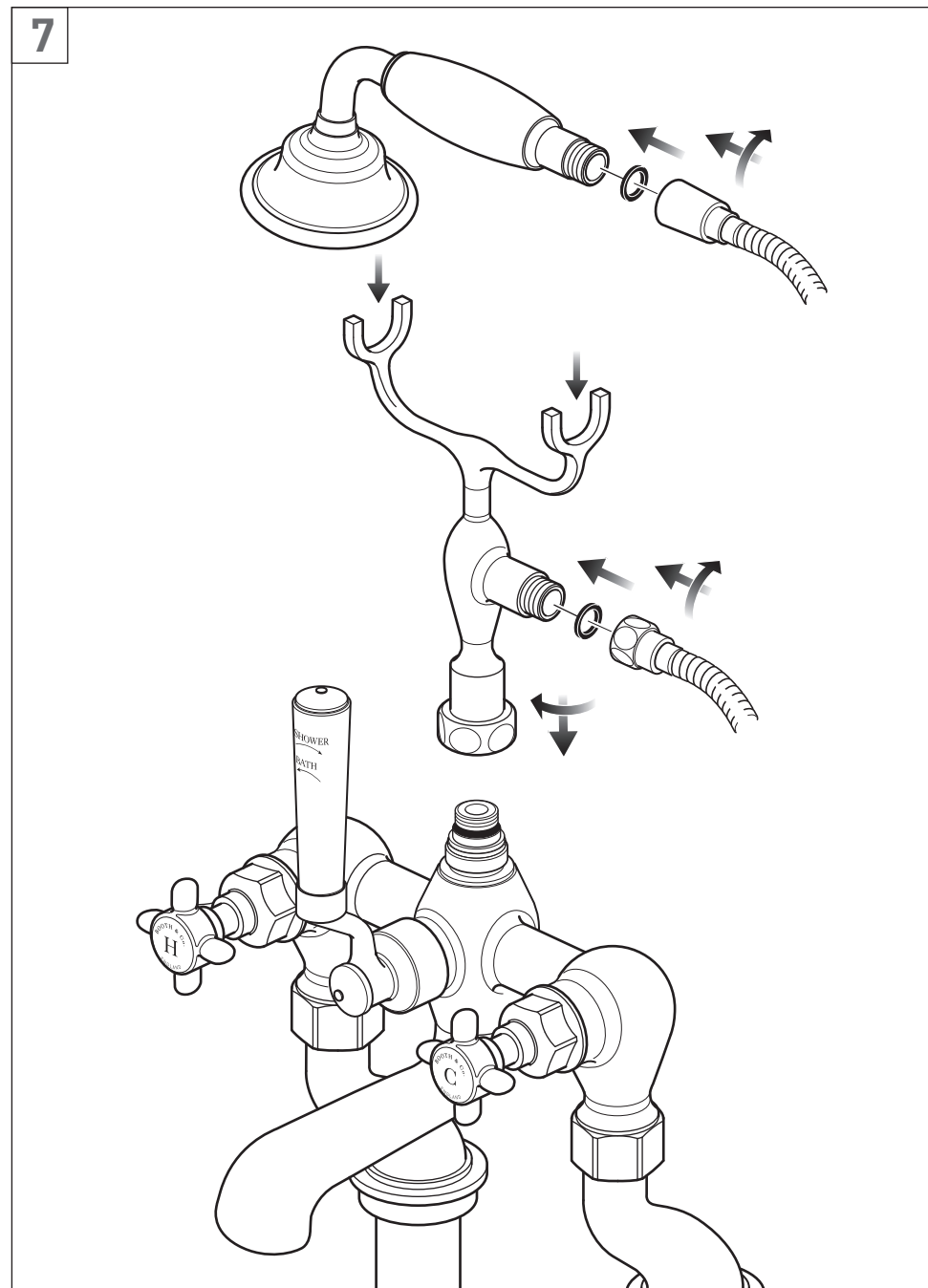

Installation - handles

The handles can be fitted before or after the main installation. For illustrative purposes only the handles are being fitted before the tap installation. Please follow the same procedure to fit the handles after the tap has been installed.

For illustrative purposes only the cross handle is shown. The same procedure applies to install the lever handle.

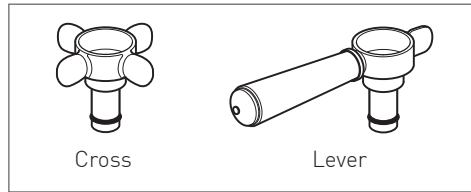

Installing the handles

Remove cover nut and valve from the tap body, and then remove the lock nut from the valve. They should only be hand tight. See Fig. 1

Screw the valve back into the tap body. Place a handle onto splines and using light force only turn the handle clockwise until you feel a noticeable resistance when the base of valve touches down on the body of the tap.

Turn the handle so the valve is in the closed position, then remove the handle and refit back onto the spline so it is as square as possible (do not worry if it is not perfectly aligned at this stage).

Without forcing the handle, adjust the handle and the valve together so that the handle is perfectly straight making sure you do not unscrew the valve by more than 20°. Should you do so you will need to go back to the beginning of this section and start again.

Test the action of the handle and valve making sure that the handle is perfectly straight in the off position. Remove the handle. See Fig. 2

Lever handle

The lever on the handle should point down when in the off position.

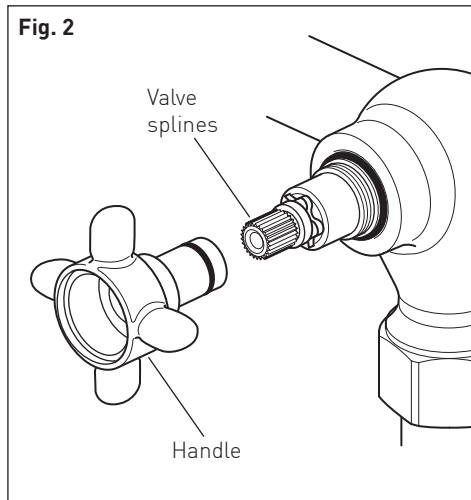
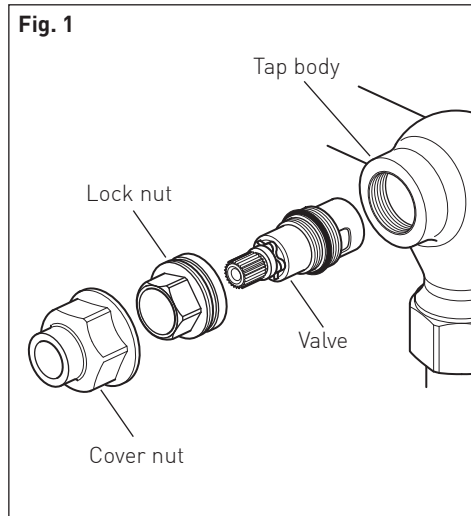

Installation - handle

Place the lock nut over the valve and screw down. Use a torque wrench to tighten the nut down to 20Nm. See Fig. 3

Screw the cover nut onto the valve, hand tight only.

Carefully slide the handle onto the splines of the valve with the handle pointing in the correct position.

See Fig. 4

Finally secure the handle in position.

Place the lock washer onto the screw and down through the handle, tighten using a cross head screwdriver.

Push on the handle cover.

See Fig. 5

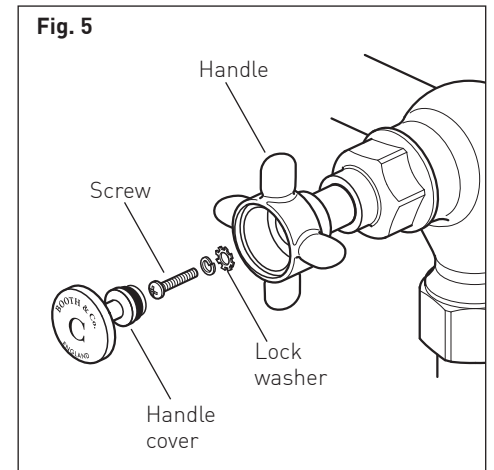
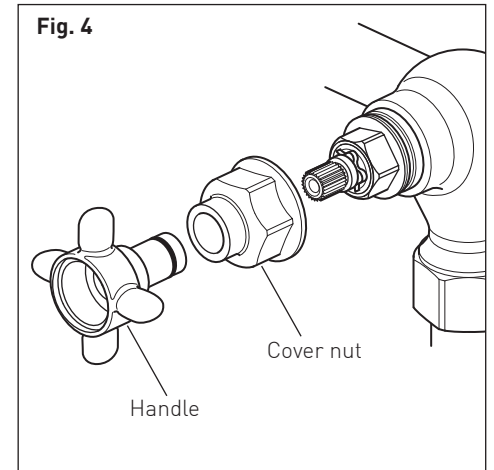
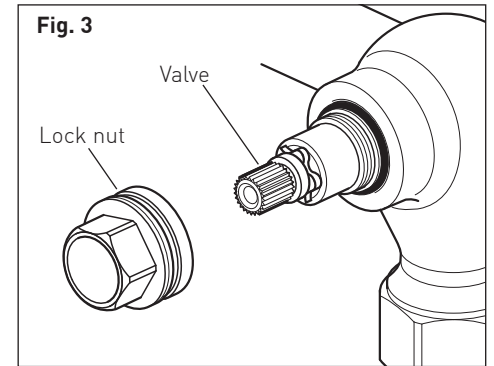

Installation

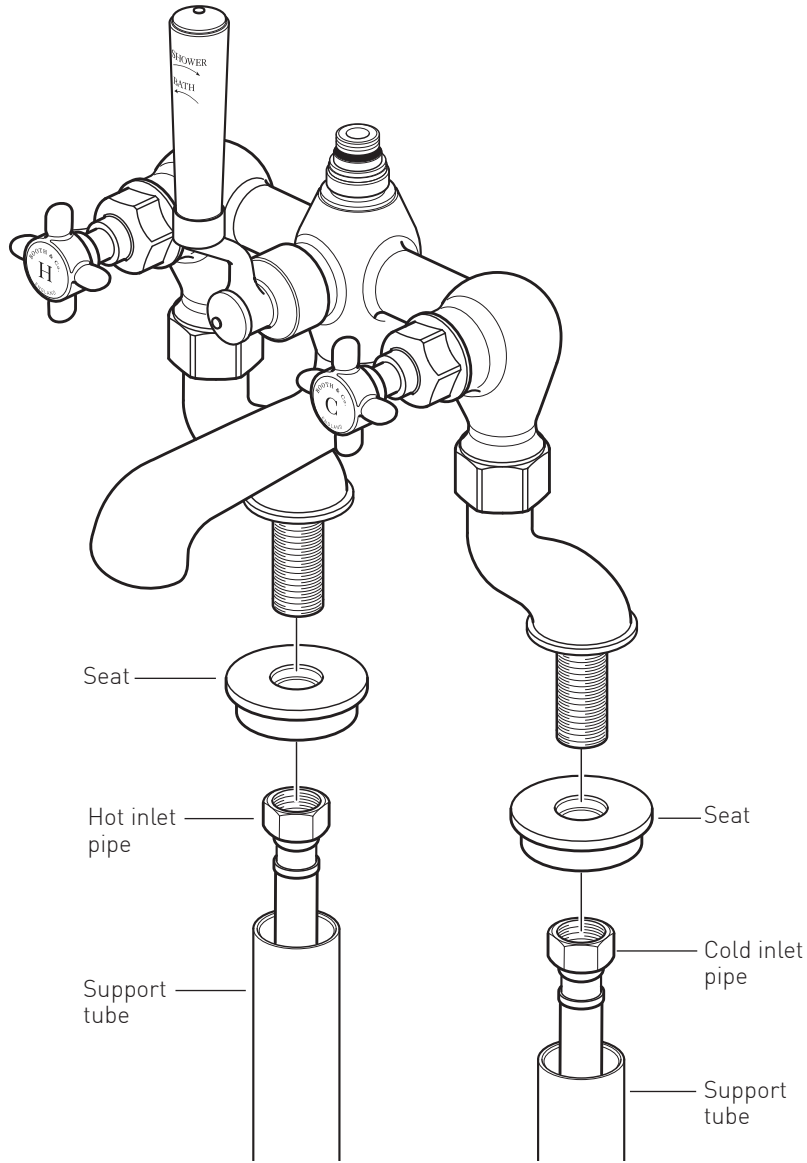

Slide both seats onto the mixer connections.
Screw the inlet pipes to the mixer connections, hot is on the left and cold on the right.
Slide the support tube up and into the base of the seat.

Installation

Prepare the floor with 2 x 1/2" male flexible connectors at 180mm centres. Connect the water supply to the connectors. The hot water should be connected to the left and cold to the right.
Note: There should be sufficient vertical movement in the inlet pipes to allow for the connection to the support tubes pipes. Flush through the pipe work to ensure removal of debris. Check for leaks and turn off the water supply.

At the bottom slide a cover onto each support tube.

Slide the foot plate over the support tube pipe and into the support tube.
Repeat for the other side.

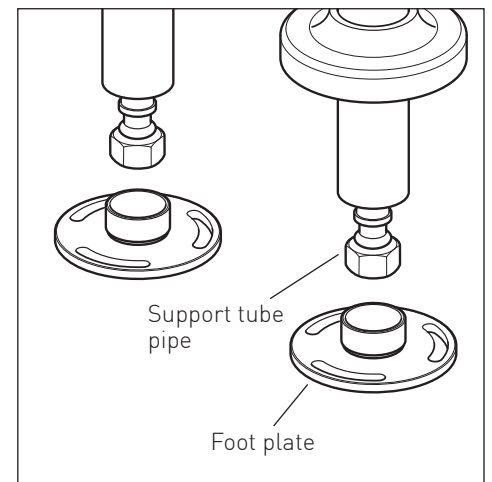
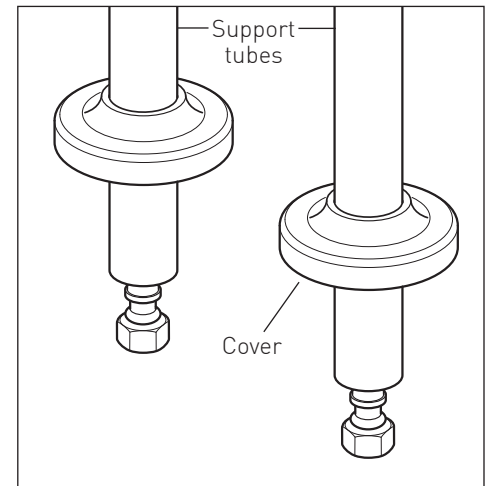
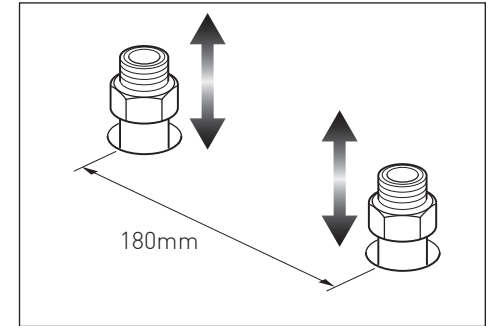

Installation

Mark the position of the 3 fixing holes in each foot plate.

Unscrew and remove the support tubes and foot plates.

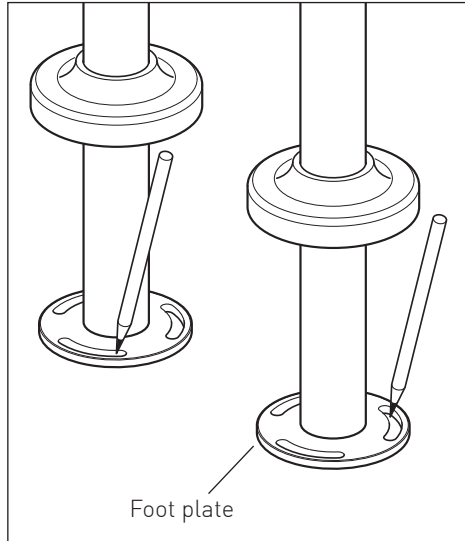

Drill the 6 holes to the required depth and diameter to suit your fixings and floor.

Connect the inlet pipes protruding from the floor to the support tube pipes.

Slide both foot plates down and fix.

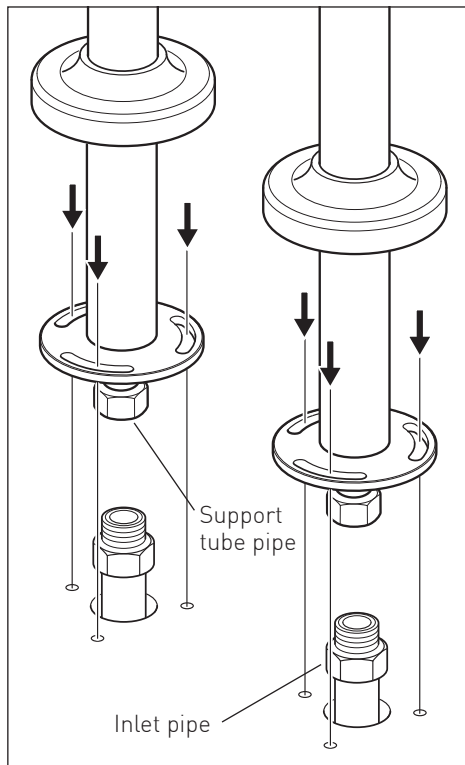

Installation

Slide both covers down until they contact the floor.

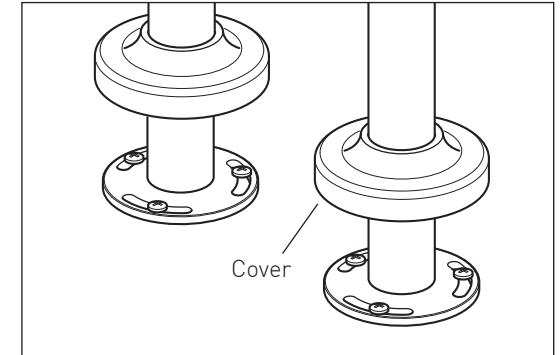

Carefully screw the handset holder onto the valve. Make sure that it is in the correct position before tightening. Be careful not to damage the surface, do not over tighten.

Handset

Place one of the rubber washers into the cone end of the hose and screw to the Handset.

Place the handset onto the holder.

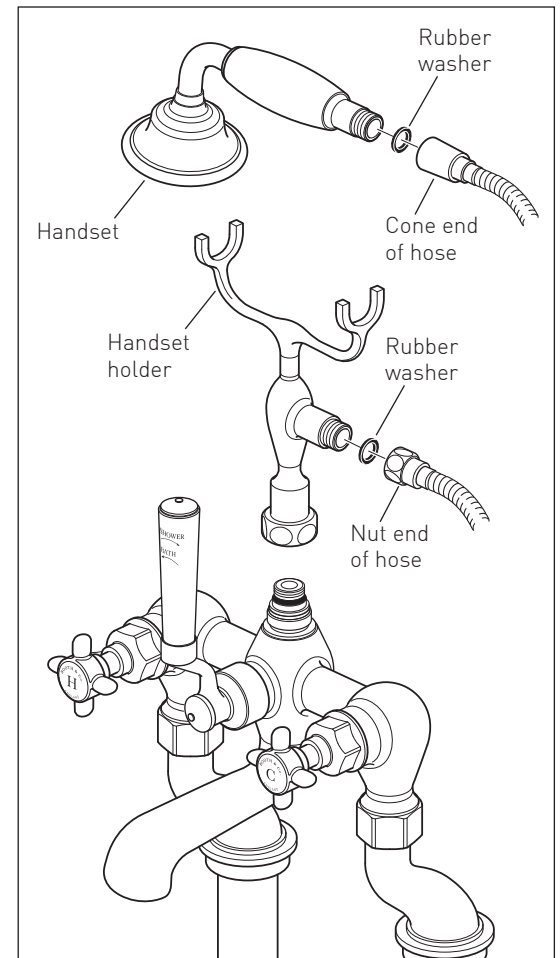

Mixer

Place the other rubber washer into the nut end of the hose and attach it to the mixer outlet.