

SPECIFICATION SHEET

COLLECTION: AXBRIDGE

PRODUCT CODE: BC-AXB-101-CP



DESCRIPTION:

Axbridge
3 Hole Basin Mixer
deck mounted
with pop-up waste
cross handles
with water flow straightener
cold ceramic cartridge FL-501-RTC
hot ceramic cartridge FL-501-LTC
4 x 1/2" x 400mm flexipipe connections
deck mount drill hole diameter 32mm
minimum operating pressure 0.2 bar LP

FINISH:

Chrome

FLOW REGULATOR:

FR-FLEXI/5-PLA (2 are required)

MINIMUM OPERATING PRESSURE:

0.2 bar LP

FLOW RATE AT 3.0 BAR FLOW PRESSURE:

15 l/min

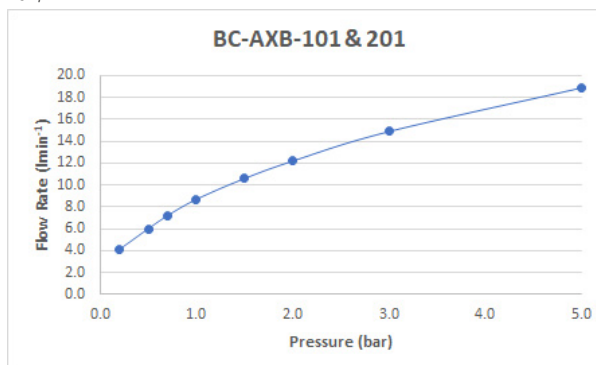

BOOTH & Co.
ENGLAND

Timeless Design. Pioneering Performance.

Your journey to distinction awaits.

TECHNICAL DRAWING

COLLECTION: AXBRIDGE

PRODUCT CODE: BC-AXB-101-CP

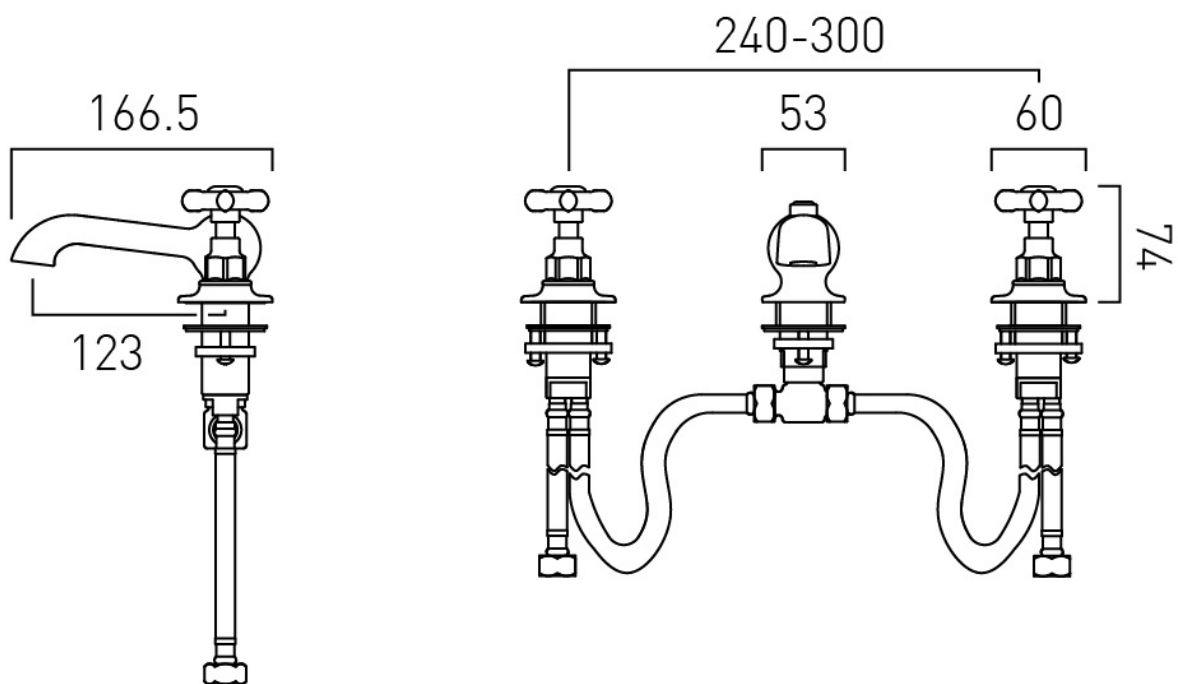

Guarantee

All VADO and Booth & Co. products come with a 2 year guarantee as standard. Within this guarantee period VADO will provide replacement parts and any labour **[SEE NOTE 1]** needed to complete the product repair.

This standard guarantee may be extended by registering your product to give up to a 15 year guarantee period. Once registered:

VADO chromed brassware and stainless steel products have a 12 year guarantee (2 years parts and labour plus 10 years parts only).

Individual by VADO and Booth & Co. products have a 15 year guarantee (2 years parts plus 13 years parts only) *with the exception of Sensori products (please see details of guarantee below).*

VADO Sensori Smart Touch and Smart Dial products have a 5 year guarantee (parts and labour).

VADO Identity and i-tech products have a 5 year guarantee (2 year parts and labour plus 3 years parts only).

All other VADO products have a 3 year guarantee (2 years parts and labour plus 1 year parts only) **[SEE NOTE 2].**

VADO electric showers have a 2 years parts and labour guarantee.

Guarantee conditions

Our products are guaranteed against manufacturing defects from the date of purchase until the expiry of the relevant guarantee period shown above.

The guarantee is only valid if:

- The product has been installed, used and maintained in accordance with VADO's instructions and subjected to normal use only.
- The defect is not due to use of an unsuitable or inadequate water or power supply.
- The defect is not due to accident, misuse, neglect or incorrect/inappropriate repair (other than by VADO or VADO authorised agents) or damage caused by foreign objects or substances.
- The extended guarantee is only available if you have completed the Guarantee Registration Process.

This can be done via the VADO website or via phone to our aftersales team. Registration must be completed within 6 months from date of purchase.

Under the extended guarantee period VADO will, at its option, offer to supply any replacement product (or component part) assessed to be defective **[SEE NOTE 3].**

The guarantee (whether standard or extended) is non-transferable to any subsequent owner. All claims under the guarantee should be notified in the first instance to our Aftersales department, contact details below, this must be done no later than the last day of the relevant guarantee period. All claims must be accompanied by proof of purchase (sales receipt or delivery note) from an official VADO dealer.

The guarantee does not extend to any consequential loss or damage.

After repair or replacement, the relevant guarantee period will be calculated from the original date of purchase.

VADO operates a policy of continuous product development and therefore reserves the right to change the product, packaging and documentation specifications without notice.

NOTES:

[1] Labour via our engineer network is only available in the UK. Attendance by a VADO engineer or sub-contract engineer will be under our standard terms and conditions.

[2] VADO spare parts and shower hoses are under a parts only guarantee.

[3] VADO reserves the right to charge in advance for a product (or replacement part) pending collection and investigation (at VADO expense) to confirm a defect is due to a manufacturing issue.

If a defect is found the charge will be refunded or cancelled. This guarantee is in addition to and does not affect your statutory rights as a consumer.

Tel: 01934 745163

Email: aftersalescare@vado.com

KEEP FOR
FUTURE REFERENCE

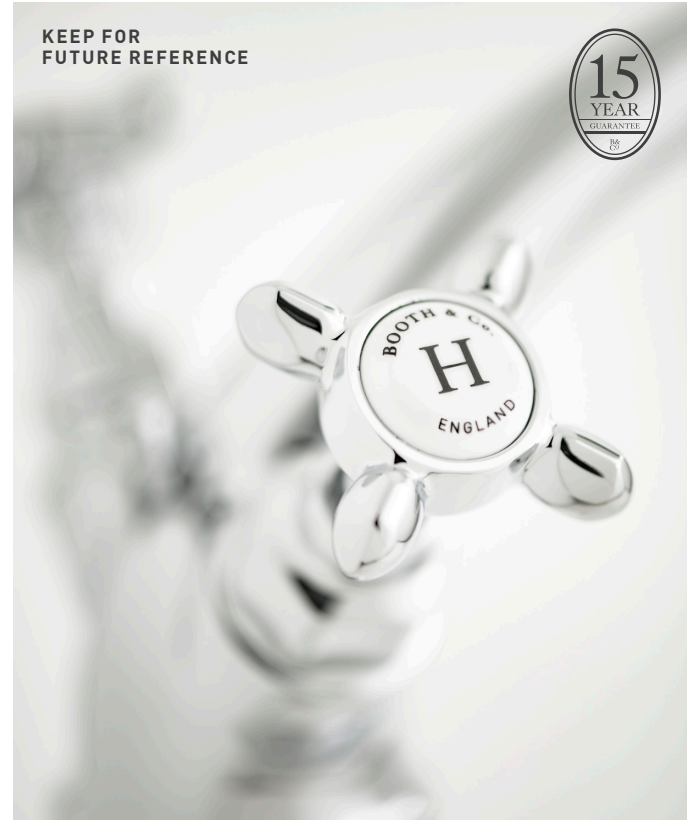

AXBRIDGE

3 HOLE BASIN MIXER
USER GUIDE

BOOTH & Co.
ENGLAND

Welcome to Booth & Co.

Expertly designed in our home town of Cheddar, Somerset, each Booth & Co. product is as time-honoured on the outside as it is pioneering within.

Hand-crafted to exude a distinct, timeless sophistication, this product has passed through stringent quality assurance processes and demanding lifecycle mechanical testing to ensure an unrivalled quality.

Our leading 15 year guarantee certifies excellence within every detail.

Part of the VADO family, Booth & Co. retains the same outstanding customer service and large scale development support that earned VADO a globally trusted reputation. For any technical or operation queries, please contact our experienced Aftersales team on 01934 745 163.

Indulge in luxury as it should be.

VADO
Wedmore Road, Cheddar,
Somerset, England BS27 3EB
tel 01934 744466
fax 01934 744345
www.vado.com
sales@vado.com

Cleaning instructions:

The electroplating on this product is finished to the highest standard. Due care needs to be taken to ensure the appearance is retained.

We recommend cleaning all products with a soft damp cloth ONLY and advise strongly against the use of all aggressive/corrosive cleaning products i.e. powders and liquids. If these instructions are not followed, this may invalidate your guarantee in the event of a problem occurring.

Operation - cross handles

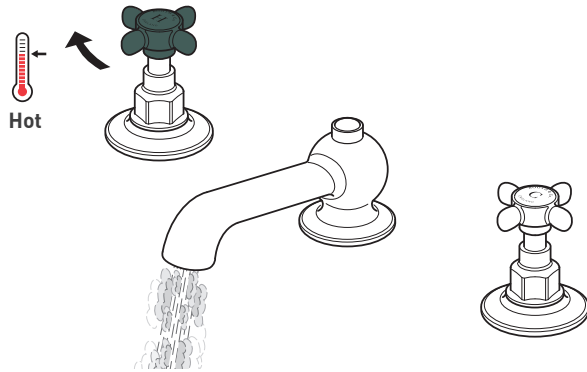

Turning the hot handle clockwise will increase the flow of hot water.

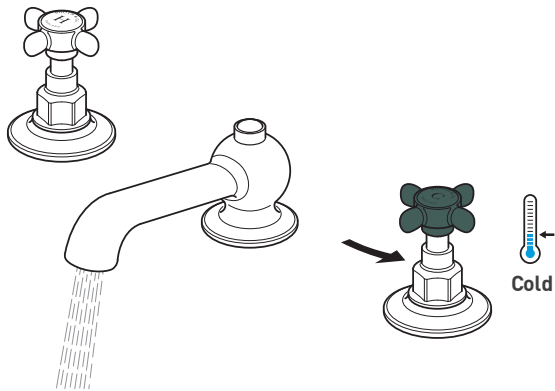

Turning the cold handle anti-clockwise will increase the flow of cold water.

Operation - lever handles

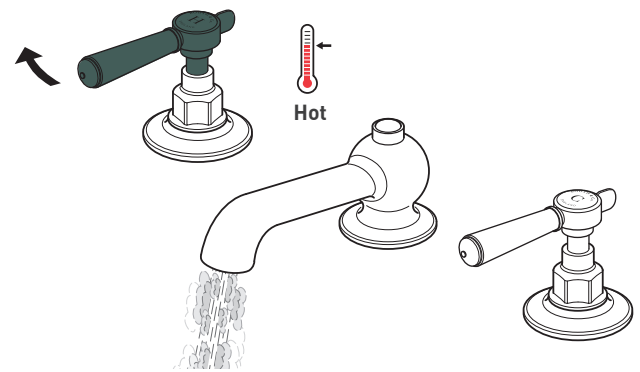

Turning the hot handle clockwise will increase the flow of hot water.

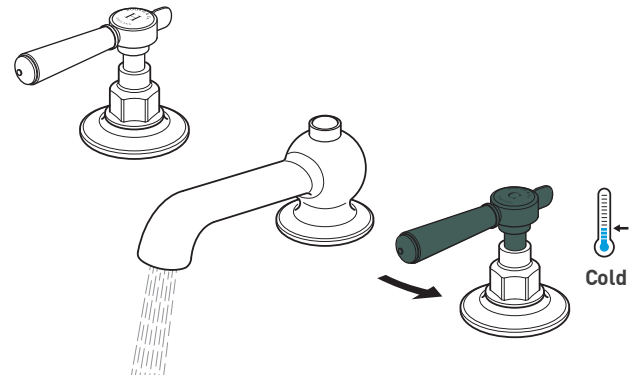

Turning the cold handle anti-clockwise will increase the flow of cold water.

Operation - pop-up waste

Notes:

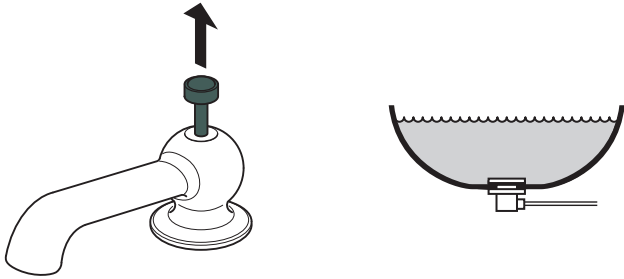

Pull the waste control rod up to close the plug and fill the basin.

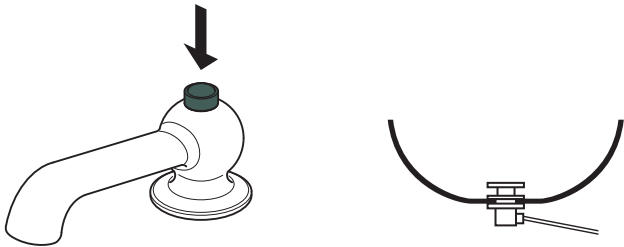

Push the waste control rod down to open the plug and empty the basin.



BOOTH & Co.

ENGLAND

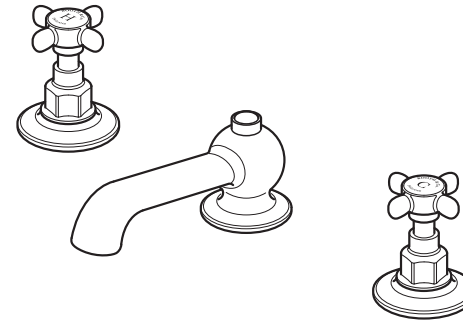

This instruction booklet covers model:

- BC-AXB-101-CP
- BC-AXB-101-BN
- BC-AXB-201-CP
- BC-AXB-201-BN

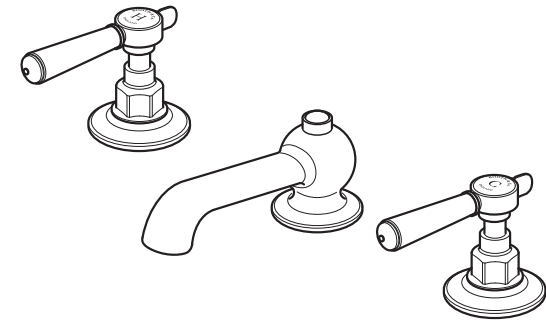

VADO
Wedmore Road, Cheddar,
Somerset, England BS27 3EB
tel 01934 744466
fax 01934 744345
www.vado.com
sales@vado.com

AXBRIDGE

BC-AXB-101-CP, BC-AXB-101-BN
BC-AXB-201-CP, BC-AXB-201-BN
INSTALLATION GUIDE

Version 1, 1-5-19

BOOTH & Co.
ENGLAND

Important - please read

Please read these instructions carefully before starting installation and keep for future reference.

Remove all packaging and check the product for missing parts or damage before starting installation.

Any alterations made to this product and fittings may infringe water regulations and will invalidate the guarantee.

The installation must comply with all Local/National Water Supply Authority Regulations/Byelaws and Building and Plumbing Regulations.
To be installed in accordance with BS EN806.

We strongly recommend that you use a qualified and registered plumber.

General installation

This fitting is a mixing device and therefore water supplies should be reasonably balanced.

When installed, the fitting must comply with the requirements of the Water Supply (Water Fittings) Regulations 1999 and Scottish Byelaws 2004.

For further information, contact the Water Regulations department of your local water supplier (see the WRAS website www.wras.co.uk for details) or the Water Regulations Advisory Scheme by email (info@wras.co.uk) or telephone: 01495848454.

Before making any inlet pipe connections, all supply pipes MUST be thoroughly flushed to remove debris. Failure to do so could result in damage or low flow from the mixer unit. Water Supply (Water Fittings) Regulations 1999 Schedule 2 Section 13.

The fitting of isolating valves to the inlet feeds is advised for ease of maintenance.

Please take great care when installing this mixer not to damage its surface.

Please note if installing in an enclosed environment, access should be left for servicing and maintenance. No costs relating to inadequate access can be accepted.

Operating Specifications

Operating Pressure

Minimum operating pressure 0.2 bar

Maximum operating pressure 5 bar

Contents of Packaging

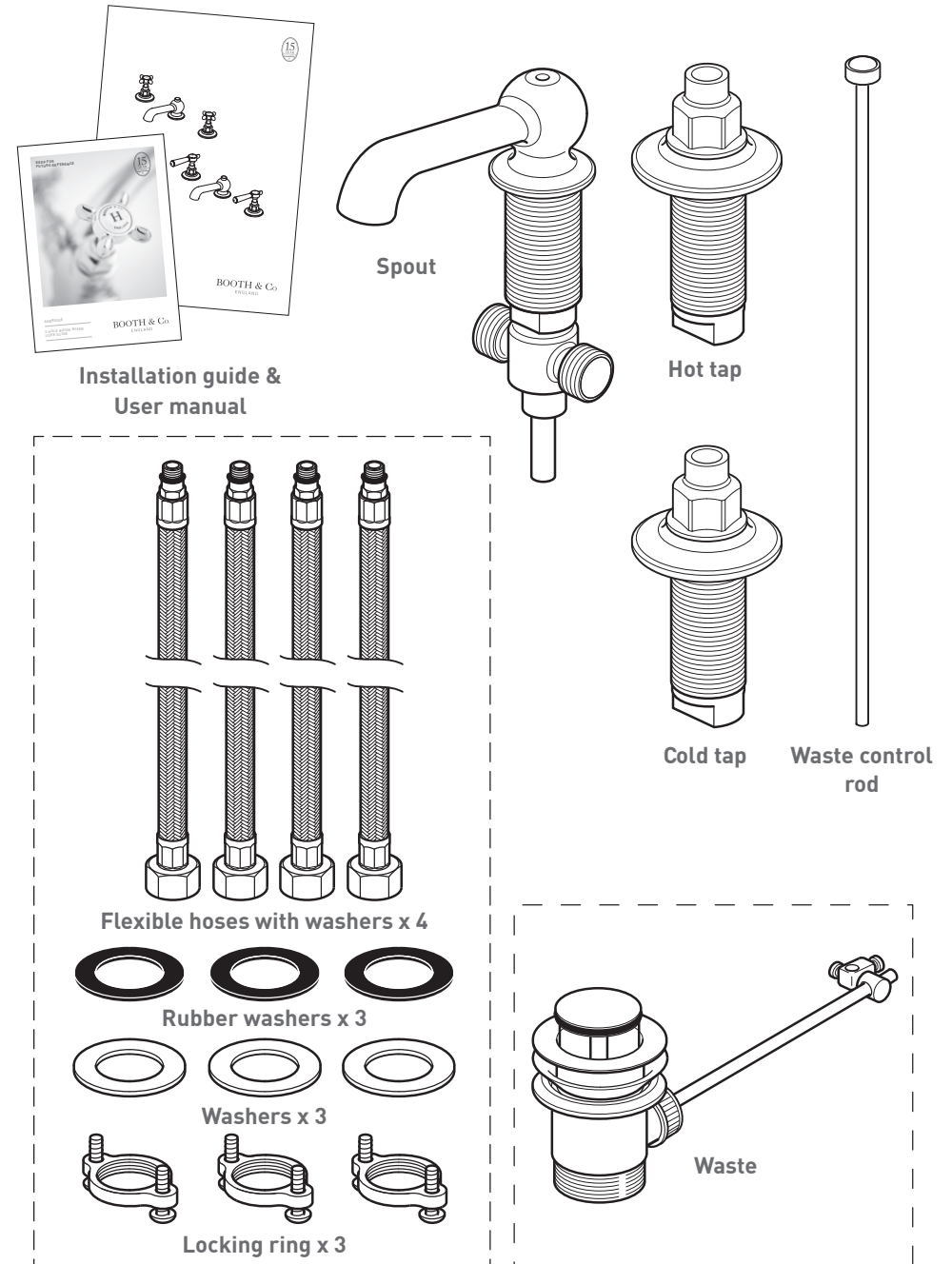

Contents of Packaging - handle options

Cross handle option OR Lever handle option

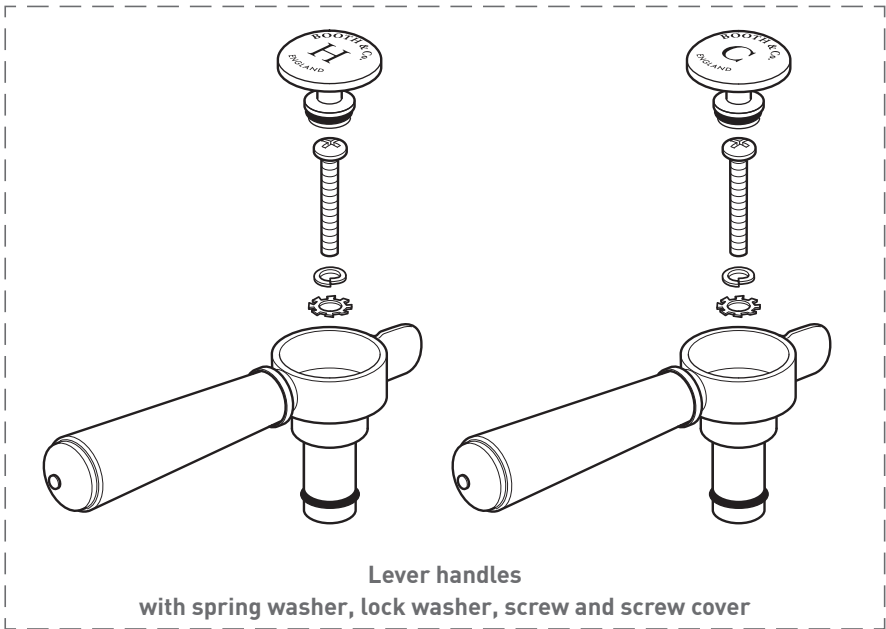
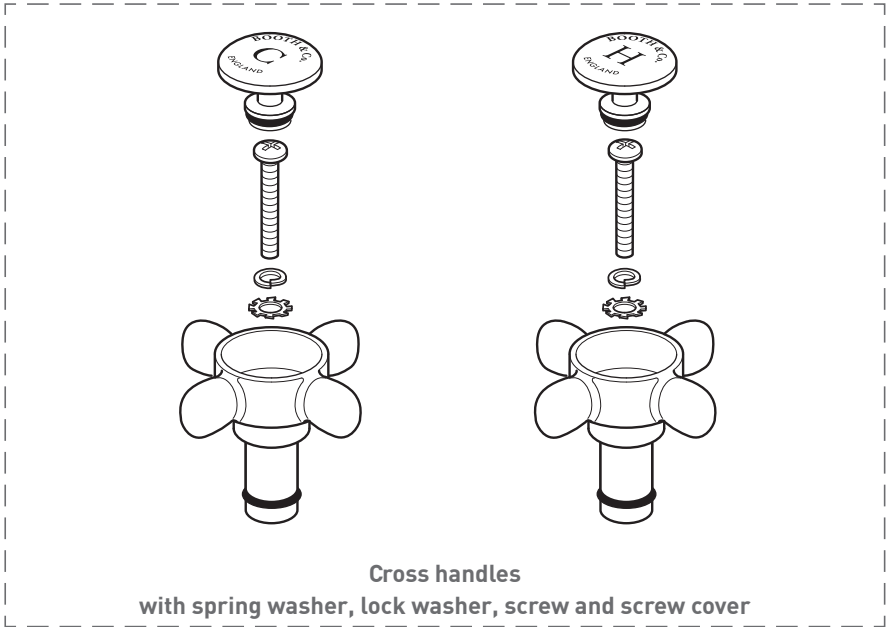

Dimensions

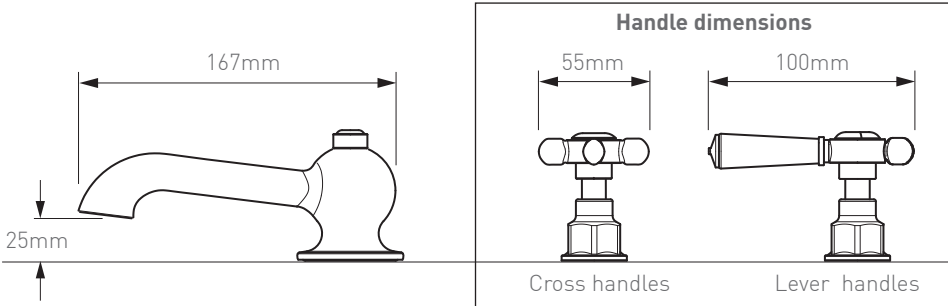
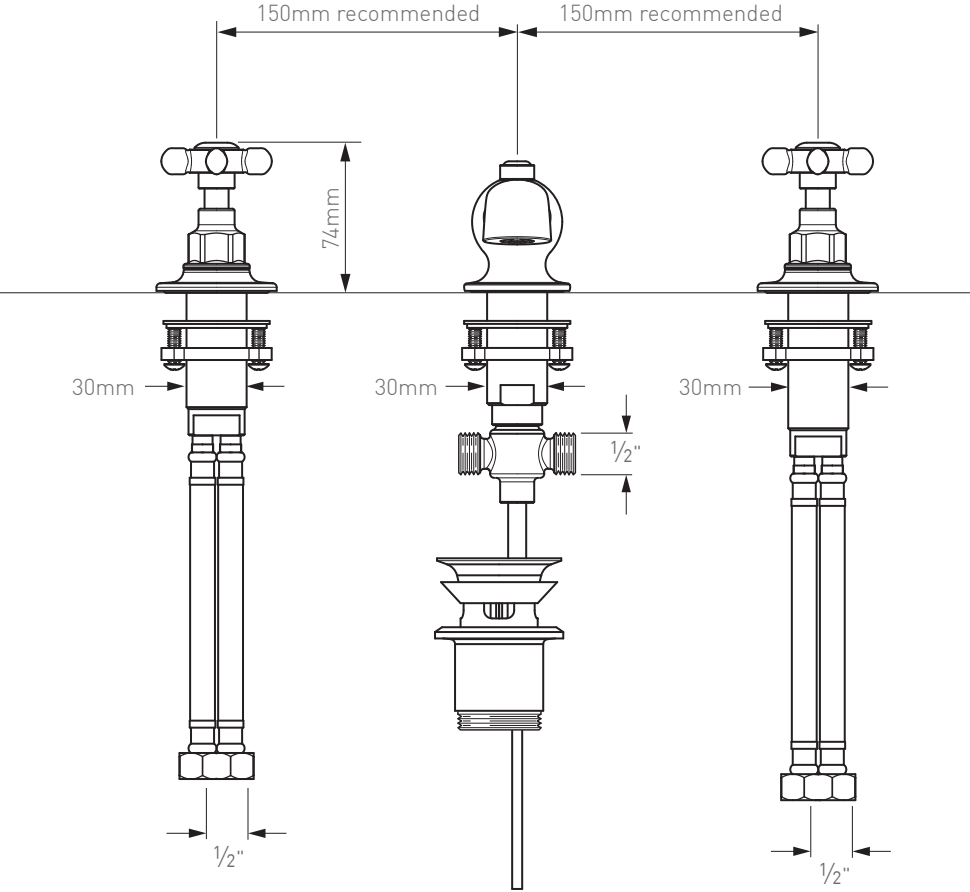

Installation - Quick guide

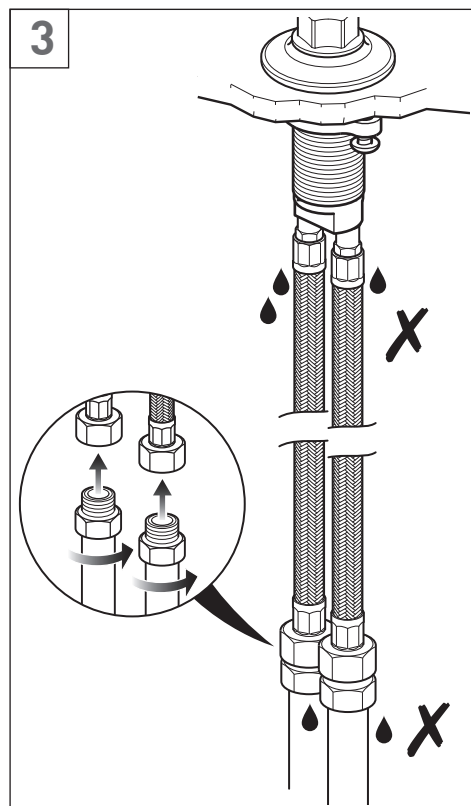
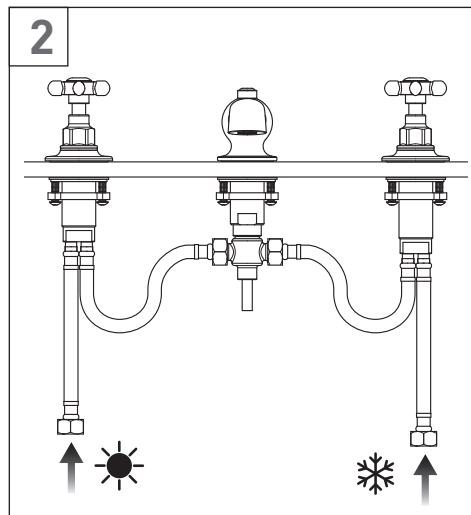
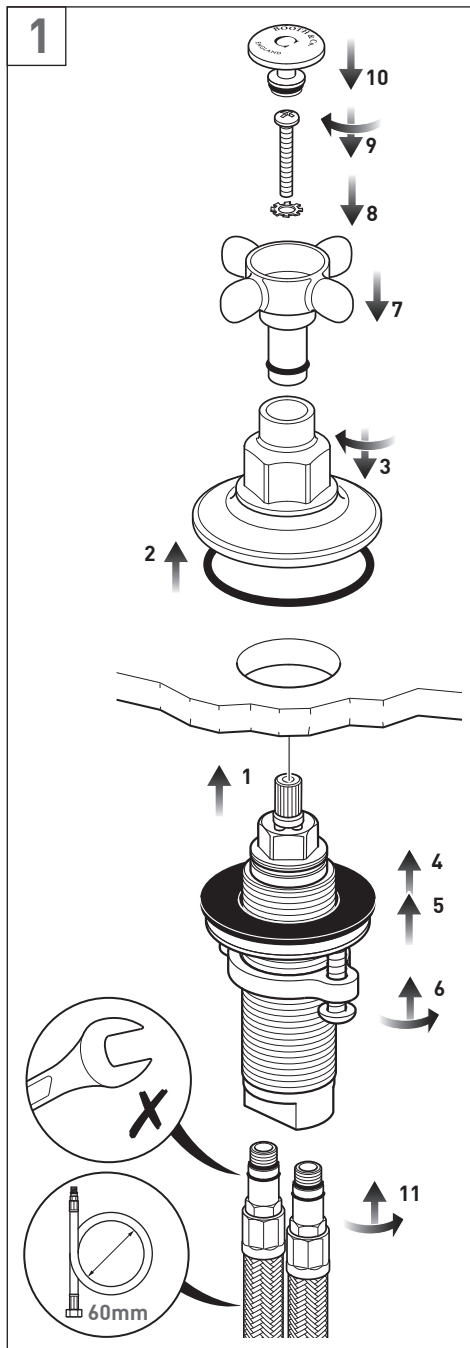

Installation - Quick guide

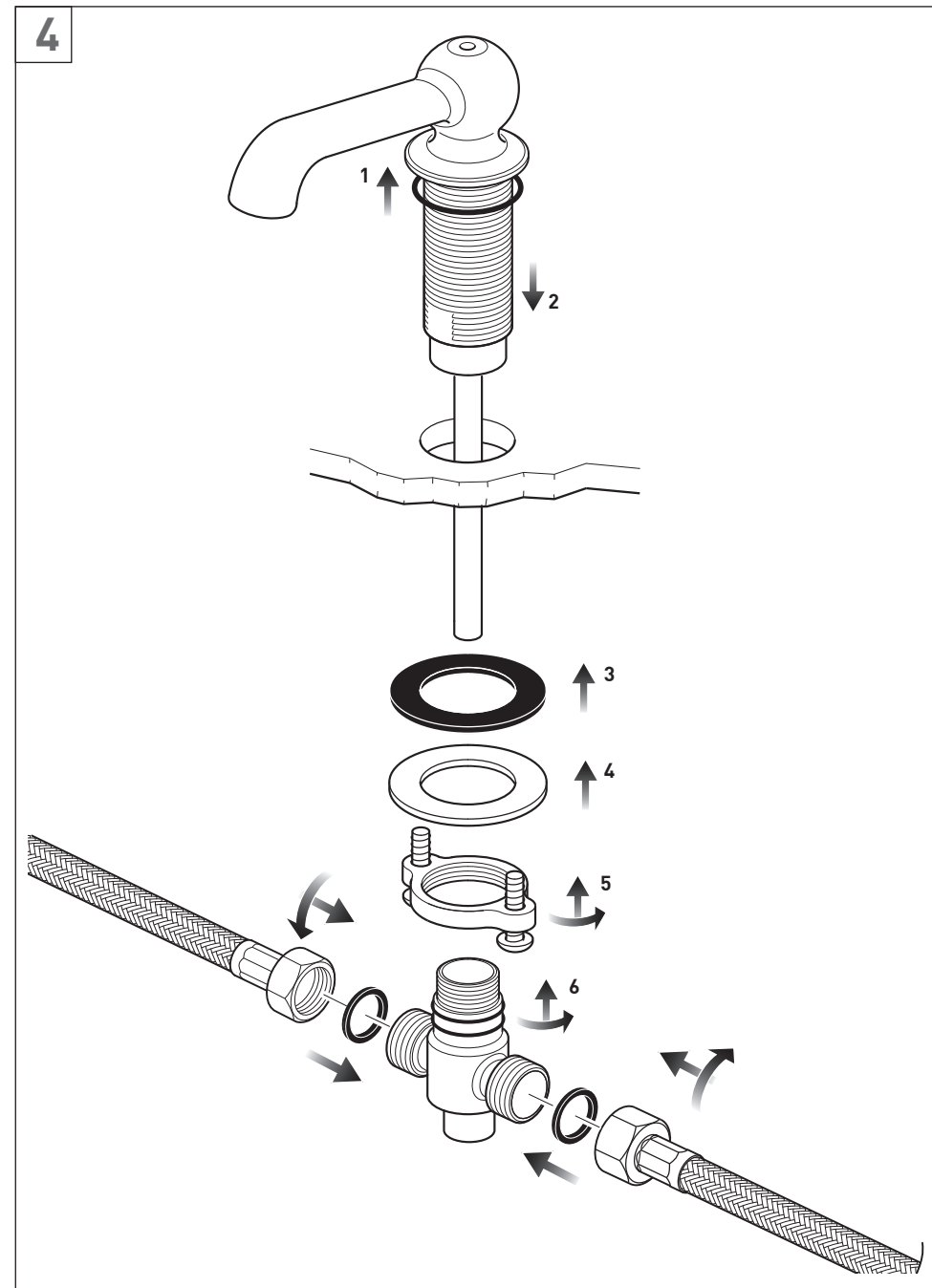

Installation - Quick guide

5

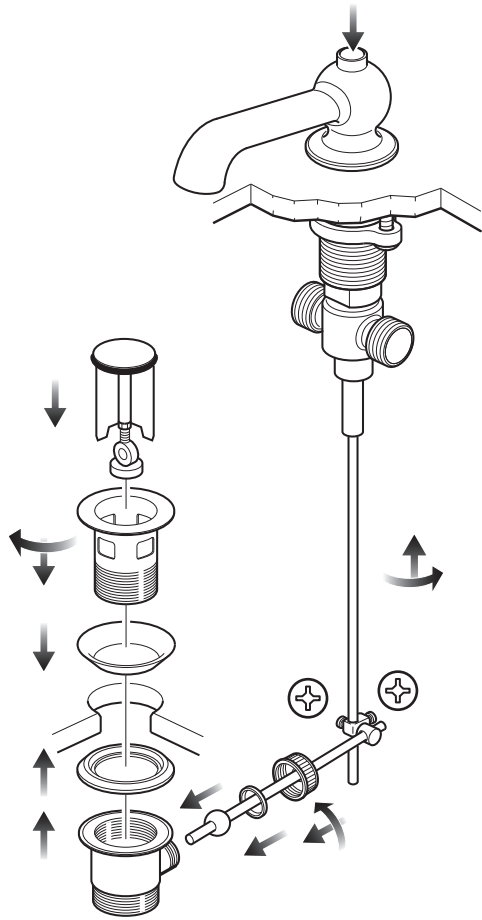

6

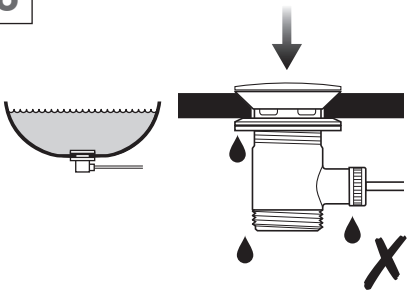

7

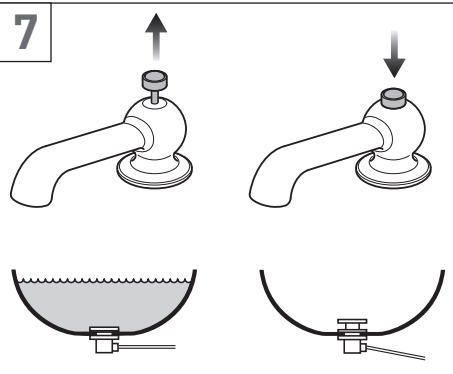

Installation - mixer

Before installing, flush through the pipe work to ensure removal of debris, turn off the water supply.

The hot tap should be on the left and cold on the right.

Remove the cover from the valve, make sure the O-ring is in place in the underside of the cover.

Screw the locking ring onto the valve make sure that the bolts are facing upwards. Slide on the metal washer followed by the rubber washer.

From the underside of the basin position the valve in place, screw on the cover and hand tighten.

Make sure the two bolts in the locking ring are unscrewed, but do not remove. Slide up the rubber and metal washer, the rubber washer should be on top.

Screw up the locking ring until the bolts touch the metal washer. Tighten the two bolts to clamp the mixer to the basin.

CAUTION: Do not over tighten the bolts as this may damage the basin.

With the valve in the off position (fully anti-clockwise for hot and clockwise for cold) carefully slide the control handle onto the splines of the valve make sure the handle is pointing in the correct direction. Secure with the lock washer and screw. Push on the screw cover.

Screw the two flexible pipes into the two holes in the base of the mixer body.

Connect the water supply.

CAUTION: When installing the flexible hoses **do not** kink, or bend them more than the 60mm diameter as shown right.

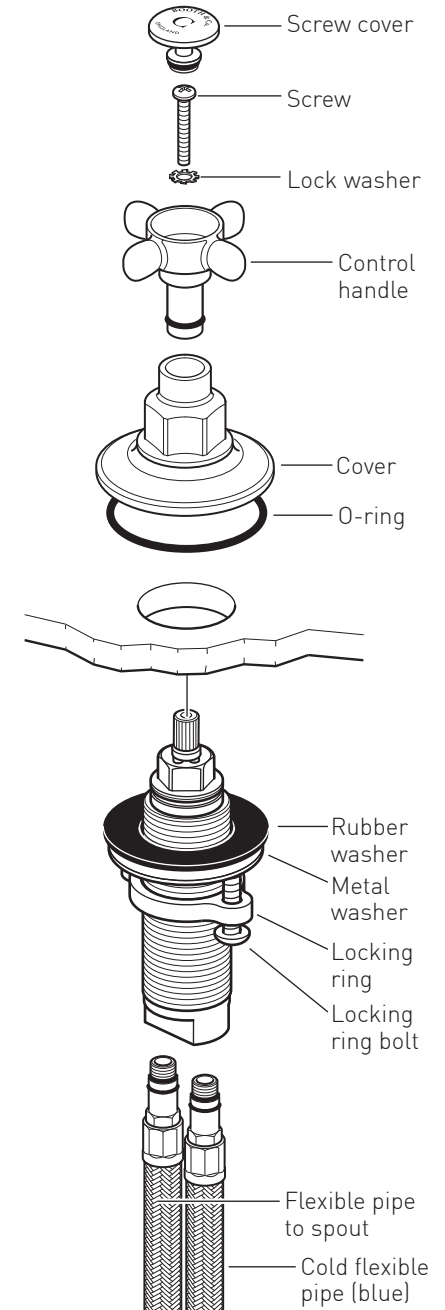
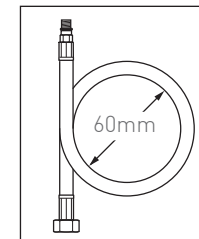

Installation - spout

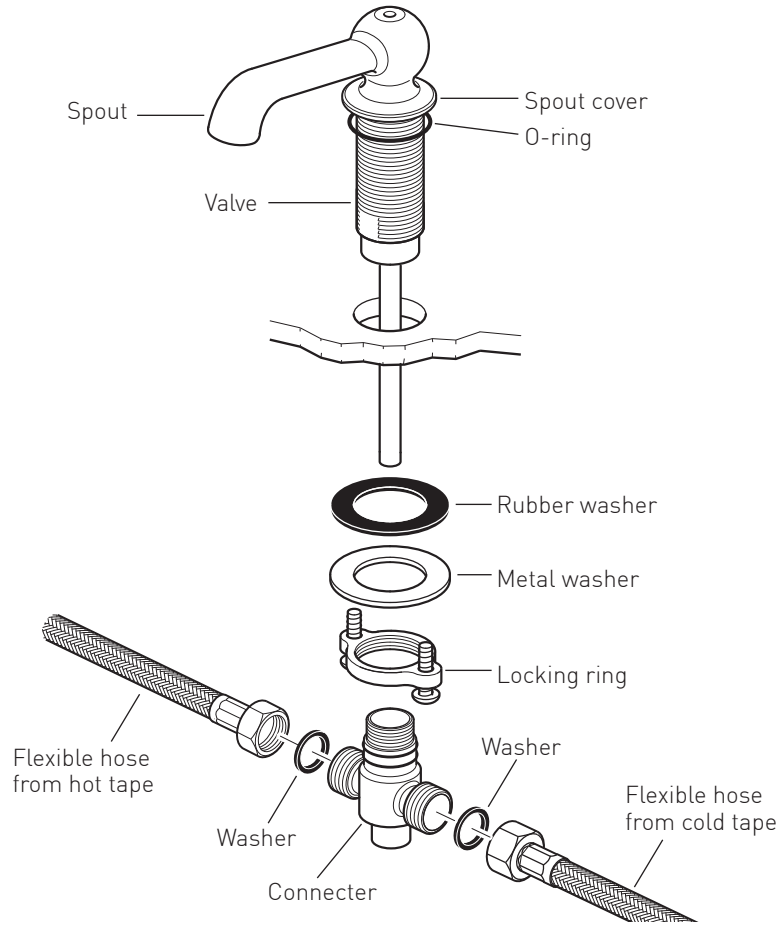

Make sure the O-ring is in place in the underside of the spout cover.

Position the the spout/valve down into the basin.

From the underside slide on the rubber and metal washer, the rubber washer should be on top.

Make sure the two bolts in the locking ring are uncrewed, but do not remove. Screw up the locking ring until the bolts touch the metal washer. Tighten the two bolts to clamp the mixer to the basin.

CAUTION: Do not over tighten the bolts as this may damage the basin.

Screw the connector onto the bottom of the valve, take care not to damage the o-rings.

Place a washer into each nut in the flexible pipe. Screw the two flexible pipes coming from the each tap into the inlets.

Installation - Pop-up waste

Insert the waste control rod down through the hole in the top of the spout body.

Place the short end of the horizontal control rod into the waste body. Slide the bearing over the control rod making sure that the chamfer is against the ball. Screw on the ball joint retainer. Do not over tighten.

Slide the control rod link onto the vertical and horizontal control rods and loosely tighten.

Test the action of the pop-up waste and fully tighten the rod link. Adjust the control rod link as required. Adjust the height of the plug as required.

Turn on the water supply and turn the mixer on fully to flush through any possible debris from the mixer. Finally check all new connections for leaks.

